



User's Manual and Operating Instructions

Model Number: PT-70-SS-A



Consumer: Please Read These Instructions And Keep For Your Reference

▲ GENERAL HAZARD WARNING

FAILURE TO COMPLY WITH THE PRECAUTIONS AND INSTRUCTIONS PROVIDED WITH THIS HEATER, CAN RESULT IN DEATH, SERIOUS BODILY INJURY AND PROPERTY LOSS OR DAMAGE FROM HAZARDS OF FIRE, EXPLOSION, BURN, ASPHYXIATION, CARBON MONOXIDE POISONING AND / OR ELECTRIC SHOCK.

ONLY PERSONS WHO CAN UNDERSTAND AND FOLLOW THE INSTRUCTIONS SHOULD USE OR SERVICE THIS HEATER.

IF YOU NEED ASSISTANCE OR HEATER INFORMATION SUCH AS AN INSTRUCTIONS MANUAL, LABEL, ETC. CONTACT THE MANUFACTURER.

▲ WARNING

This is an unvented portable heater. It uses air (oxygen) from the area in which it is used. Adequate combustion and ventilation air must be provided. Refer to VENTILATION on Page 7.

© Pinnacle Products International, Inc.

668 Stony Hill Road #302 Yardley, PA 19067 USA Toll Free: (800) 641-6996
Fax: (215) 891-8461 • Web: www.pinnacleint.com • Email: info@pinnacleint.com

NEVER LEAVE HEATER UNATTENDED WHILE BURNING, OR WHILE CONNECTED TO A POWER SOURCE.



Ultra-Portable Oil-Fired Radiant Heater

Table of Contents

Warnings..... 2
 Safety Information..... 2-3
 Specifications 3
 Features 4
 Theory of Operation 5
 Unpacking..... 5
 Fuels..... 5
 Ventilation..... 6
 Operation..... 6
 Maintenance..... 6-7
 Storage 7
 Exploded Parts Drawing..... 8
 Replacement Part Listing 9
 Wiring Diagrams..... 10
 Troubleshooting 11
 Warranty Back Page

Safety Information

▲ DANGER Carbon Monoxide poisoning may lead to death!

This is a kerosene, direct-fired, forced air heater. It is primarily intended for use for temporary heating of buildings under construction, alteration or repair. Direct-fired means that all of the combustion products of the heater enter the heated space. This appliance is rated at 98% combustion efficiency, but does produce small amounts of carbon monoxide. Carbon monoxide is toxic. Humans can tolerate small amounts of carbon monoxide, and precautions should be taken to provide proper ventilation. Failure to provide proper ventilation in according to this manual can result in death. Early signs of carbon monoxide poisoning resemble the flu. Symptoms of improper ventilation are:

- * headache * dizziness * burning of the nose and eyes
- * nausea * dry mouth * sore throat *

If the heater is being used in the presence of others, be sure to inform them of all proper safety precautions, operating procedures and hazards. **Some people are more affected by carbon monoxide than others.** These are pregnant women, people with heart or lung disease or anemia, those under the influence of alcohol or at high altitudes.

- Check the heater thoroughly for damage before each use. DO NOT operate a damaged heater.
- DO NOT modify this heater or operate a heater that has been modified from it's original state.
- NEVER use gasoline, naphtha, paint thinner, alcohol or other fuels of any kind to operate this heater.
- **Suitable for outdoor use.** Provide at least 3 square feet of opening per 100,000 Btu of rated operation (See page 6).
- Keep heater area free from combustible materials such as gasoline, paint thinners and other flammable vapors and liquids. Dust is combustible. Do not use heater in areas of high dust concentration.

Minimum clearance from Combustibles:

	<u>Top</u>	<u>Sides</u>	<u>Front</u>
70k	4 ft.	4 ft.	8 ft.

▲ WARNING FIRE, BURN, INHALATION, AND EXPLOSION HAZARD. KEEP SOLID COMBUSTIBLES, SUCH AS BUILDING MATERIALS, PAPER OR CARDBOARD, A SAFE DISTANCE AWAY FROM THE HEATER AS RECOMMENDED BY THESE INSTRUCTIONS. NEVER USE THE HEATER IN SPACES WHICH DO OR MAY CONTAIN VOLATILE OR AIRBORNE COMBUSTIBLES, OR PRODUCTS SUCH AS GASOLINE, SOLVENTS, PAINT THINNERS, DUST PARTICLES OR UNKNOWN CHEMICALS.

▲ WARNING NOT FOR HOME OR RECREATIONAL USE.

▲ WARNING Do not operate this heater until you have read, and thoroughly understand these safety and operating instructions.

▲ WARNING California Residents: Combustion by-products produced when using this product contain carbon monoxide, a chemical known to the state of California to cause cancer and birth defects (or other reproductive harm).

▲ WARNING This product contains chemicals, including lead, known to the State of California to cause birth defects or other reproductive harm. **Wash hands after handling.**

Massachusetts Residents: Massachusetts state law prohibits the use of this heater in any building which is used in whole or in part for human habitation. Use of this heating device in Massachusetts requires local fire department permit (M.G.L.C. 148, Section 10A).

New York City Residents: The New York City Fire Code prohibits the storage, handling and use of kerosene fueled heaters for space heating. Any person violating that provision may be punished by a fine up to \$10,000 and a term of imprisonment up to 6 months.

▲ WARNING This is an unvented portable heater. It uses air (oxygen) from the area in which it is used. Adequate combustion and ventilation air must be provided. Refer to VENTILATION Page 6.

▲ WARNING This heater is not suitable for use with Bio-Diesel; use of Bio-Diesel will damage the filter and seals. Damage caused by use of Bio-Diesel will not be covered by warranty.

NEVER LEAVE HEATER UNATTENDED WHILE BURNING, OR WHILE CONNECTED TO A POWER SOURCE.



Ultra-Portable Oil-Fired Radiant Heater

Safety Information (Continued)

- Operate only on level and stable surfaces.
- Do not restrict inlet or outlet of heater. Heater is never to be used with ductwork.
- NEVER leave heater unattended.
- Keep children and animals away from heater.
- To prevent injury, always wear gloves when handling heater. Never handle an operating or hot heater, as severe burns may result.
- This heater is not for use on finished floors.
- Use heater in accordance to local codes and Federal Ordinances.
- Use only the electrical/power cord specified. Electrical and grounding connection must comply with National Electrical Code - ANSI/NFPA 70 (USA) and CSA C22.1 Canadian Electrical Code, Part 1 (Canada).
- NEVER use heater in occupied dwellings.
- Operate heater in a manner that will not directly expose it to water, rain or dripping water.

Specifications

Model #	PT-70-SS-A
Rating BTU/Hr	70,000
Volts / Hz	AC 120V / 60 Hz
Fuel Consumption (Gal/Hr)	0.5
Fuel Tank Capacity (Gallons)	4
Max Operating Hours	7.0
Heat Type	Radiant + Fan Forced
Heating Area (Sq Ft)	1,750
Overheat Shut-Off System	Yes
Size (L x W x H)	20.9" x 14.4" x 22"
Weight (Lbs)	30

Figure 1. Model Specifications

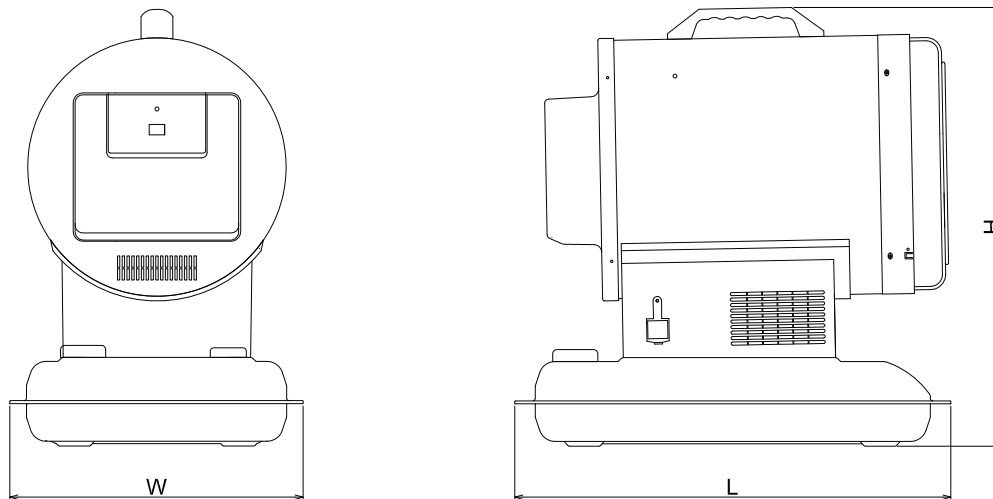

Figure 2. Product Dimensions

Specifications subject to change without notice

Model No.	Length	Width	Height
PT-70-SS-A	20.9"	14.4"	22"

NEVER LEAVE HEATER
UNATTENDED WHILE BURN-
ING, OR WHILE CONNECTED
TO A POWER SOURCE.



Ultra-Portable Oil-
Fired Radiant Heater

Features

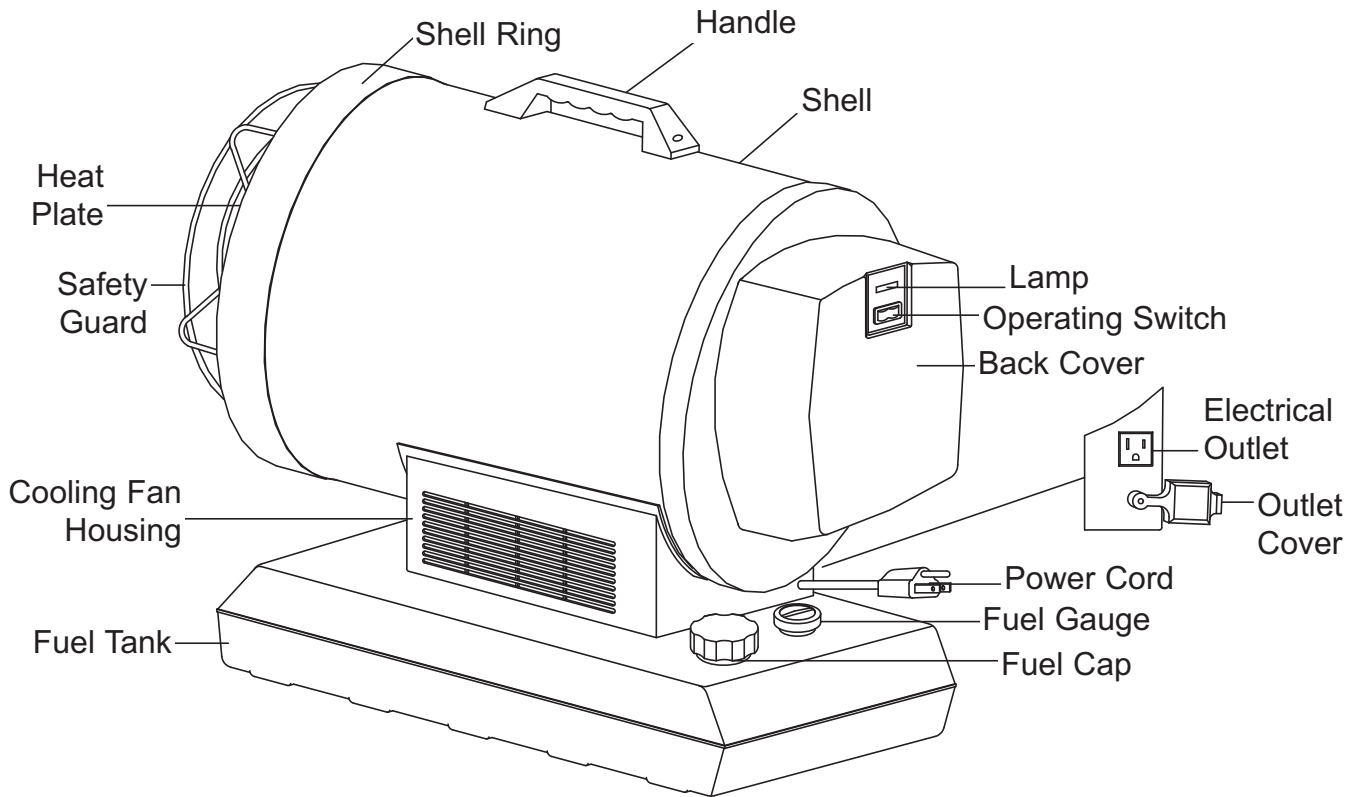

Figure 3. Features

NEVER LEAVE HEATER UNATTENDED WHILE BURNING, OR WHILE CONNECTED TO A POWER SOURCE.



Ultra-Portable Oil-Fired Radiant Heater

Theory of Operation

Fuel System: This heater is equipped with a high-pressure pump. The pump draws fuel up from the fuel tank to the nozzle in the burner head. It is sprayed into the combustion chamber in a fine mist where it is mixed with air for combustion.

Quick-Fire Ignition: A transformer sends high voltage to a two-pronged spark plug. The spark ignites the fuel/air mixture as it is sprayed into the combustion chamber.

Air System: A blower motor assembly forces air around the combustion chamber, where it is super-heated and forced out the front of the chamber. A cooling fan blows air up and around the chamber during operation and also runs during the cool-down period.

Electrical System Protection: The heater's electrical system is protected by a circuit breaker that protects the system components from damage. If the heater fails, check the fuse first, and replace if necessary (see page 10).

Flame Sensor: The heater uses a photocell to see the flame in the combustion chamber. Should the flame extinguish, the sensor will stop electrical current and the heater will shut off.

Unpacking Heater

1. Attach handle by lining up holes of handle with the holes in the upper shell of heater (See figure 4).
2. Insert screws and tighten.
3. Remove the heater and all of the packaging materials from the shipping carton.

NOTE: Save the box and packaging materials for future storage.

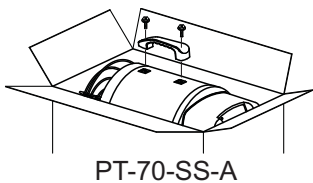

Figure 4. Attaching the handle

Fuel (1-K Kerosene)

For optimal performance of this heater, it is strongly suggested that 1-K kerosene be used. 1-K kerosene has been refined to virtually eliminate contaminants, such as sulfur, which can cause a rotten egg odor during the operation of the heater. However, #1 or #2 fuel oil (diesel fuel) may also be used if 1-K kerosene is not available. Be advised that these fuels do not burn as clean as 1-K kerosene, and care should be taken to provide more fresh air ventilation to accommodate any added contaminants that may be added to the heated space. Using diesel fuel can cause excess soot production. DO NOT use any fuel that is not approved above. Do not use Bio-Diesel as this fuel will damage your heater's seals and filter.

▲ WARNING *Never use fuels such as gasoline, benzine, alcohol, white gas, camp stove fuel, paint thinners or other oil products to fuel this heater. These are volatile fuels that could cause an explosion or uncontrolled flame.*

Kerosene should only be transported or stored in a blue container that is clearly marked "kerosene". Never store kerosene in a red container, because red containers are associated with gasoline.

Never store kerosene in a living area. Kerosene should always be stored in a well ventilated area outside of the living space.

Never store kerosene in direct sunlight or near any heating source.

Never use kerosene that has been stored from one season to the next. Kerosene does break down over time. **Old kerosene will not burn properly in this heater. Use of old or contaminated kerosene can lead to excessive soot production.**

Fueling the Heater

Never fill the fuel tank indoors. Always fill the tank outdoors. Be sure that the heater is on level ground when fueling, and never overfill the fuel tank.

It is always a good idea to fire the heater outdoors for the first time. This will allow any oils used in the manufacturing process to be burned off in a safe environment. This initial burn should last at least 10 minutes.

▲ WARNING *Never refuel this heater while it is hot or operating. Fire or explosion could result.*

Never transport this heater in a vehicle while containing fuel.

▲ WARNING *This heater is not suitable for use with Bio-Diesel; use of Bio-Diesel will damage the filter and seals. Damage caused by use of Bio-Diesel will not be covered by warranty.*

NEVER LEAVE HEATER UNATTENDED WHILE BURNING, OR WHILE CONNECTED TO A POWER SOURCE.



Ultra-Portable Oil-Fired Radiant Heater

Ventilation

▲WARNING Always provide a fresh air opening in the heated space of at least three square feet (2,800 sq. cm) for each 100,000 BTU/Hr. of heater output. Provide a larger opening if more heaters are being used. As an example, an PT-70-SS-A heater will require:

- a two-car garage door open 6 inches, or
- a single car garage open 9 inches, or
- two thirty two inch wide windows open fifteen inches.

Operation

▲WARNING *Do not use this product with any accessory thermostat device or any other device that will interrupt power to the heater and bypass the required cool down cycle.*

To Start the Heater

1. Fill the tank with kerosene until fuel gauge points to "F".
2. Be sure fuel cap is secure.
3. Plug power cord into three prong, grounded extension cord and plug extension cord into three prong 120v grounded outlet. The extension cord should be at least six feet long.

Extension cord wire size requirements are as follows:

- 6 to 10 feet (1.8 to 3 meters), use 18 AWG wire.
 - 11 to 100 feet (3.4 to 30.4 meters), use 16 AWG wire.
 - 101 to 200 feet (30.8 to 61 meters), use 14 AWG wire.
4. Push the Operating switch to the "ON" position. The power indicator lamp will light and the heater will start.

NOTE: *On first ignition or after refueling, you may hear a grinding sound just before ignition. This is the fuel pump removing the air from the fuel line. Your heater will start up within seconds. If it does not start repeat Step #4 with fuel gauge reading at least 1/2 tank.*

NOTE: *The electrical components of this heater are protected by a fuse mounted in the PC board. If the heater fails to fire, check this fuse first, and replace if necessary. Also check the power source to be sure that the proper voltage is being provided to the heater.*

To Stop the Heater

1. Turn the Operating switch to "OFF" position. Combustion will stop, and the Cooling Cycle (approx. 4-5 minutes) will begin.
2. When Cooling Cycle is completed (fan stops running), it is safe to unplug the heater.
 - Unplugging the heater before the Cooling Cycle has ended may cause overheating, damage to the heater, and could void the warranty.

▲CAUTION *Do not disconnect the power source or unplug the power cord until the cooling cycle has been completed!*

To Restart the Heater

1. Wait ten seconds after cooling cycle has completed.
2. Turn the Operating Switch to "ON" position.
3. Be sure to follow all starting procedure precautions.

Electrical Outlet

▲WARNING **Shock Hazard!**

- Never plug in an appliance with more than a 5 amp rating into this outlet.
- Always keep outlet covered when not in use.

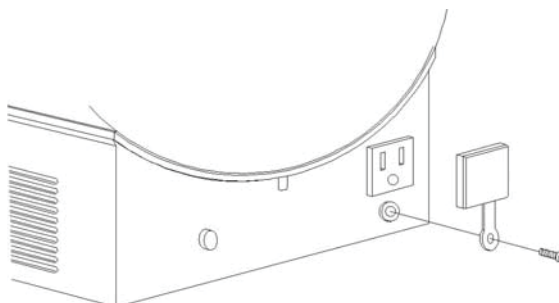

Figure 5. Electrical Outlet Assembly detail

▲WARNING *Never service heater while hot or still connected to electrical source.*

Maintenance

NEVER OPERATE THIS HEATER UNATTENDED!

Use only original equipment replacement parts. The use of alternate or third party components can cause unsafe operating conditions, and will void your warranty.

We suggest following a maintenance schedule as follows:

Filters - The Fuel Filter and Oil Filter should be cleaned at least twice per heating season by rinsing it in clean 1-K kerosene. Contaminated fuel could make this necessary immediately (see Figure 6).

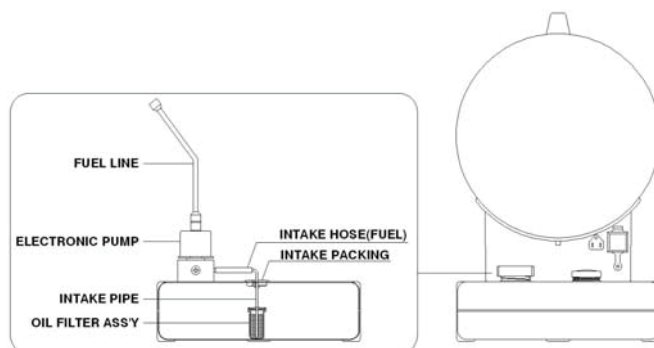

Figure 6. Filter Maintenance

NEVER LEAVE HEATER UNATTENDED WHILE BURNING, OR WHILE CONNECTED TO A POWER SOURCE.



Ultra-Portable Oil-Fired Radiant Heater

Maintenance (Continued)

Fan Blades -

- ▲ WARNING** Never service heater while hot or still connected to electrical source. The fan blades should be cleaned at least once per heating season, depending on conditions.
- Remove all accumulated dust and dirt with a burst of condensed air (**Figure 7**).

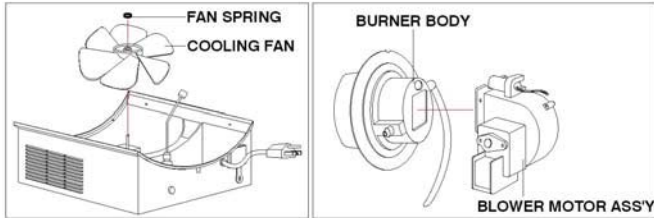

Figure 7. Fan Maintenance

Nozzles - Nozzles should be cleaned or replaced at least once per heating season. Contaminated fuel could make this necessary immediately.

- To clean dirt from nozzle, blow compressed air through nozzle front. It may be necessary to soak nozzle in clean 1-K kerosene to help loosen any particles (**Figure 8**).

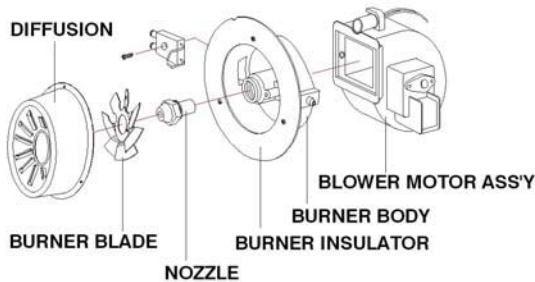

Figure 8. Nozzle Maintenance

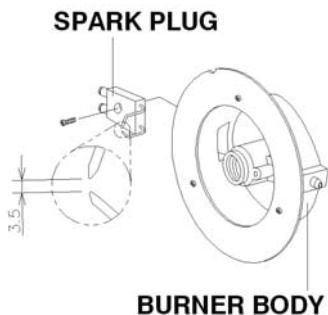

Figure 9. Spark Plug Maintenance

Spark Plug - Clean and re-gap every 600 hours of operation, or replace as needed.

- After removing the Spark Plug, clean the terminals with a wire brush. Re-gap the terminals to 0.140" (3.5mm).

Photocell - The Photocell should be cleaned at least once per heating season or more depending on conditions. Use a cotton swap dipped in water or alcohol to clean the lens of the Photocell. Note the proper Photocell position as noted in **Figure 10**.

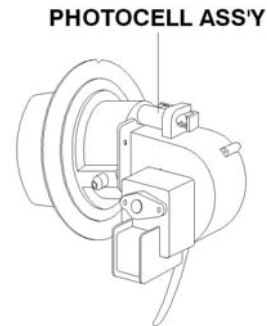

Figure 10. Photocell position

Fuel/Fuel Tank - Flush every 200 hours of operation or as needed. Do not use water to flush the tank. Use fresh 1-K kerosene only.

▲ CAUTION Failure to operate this heater according to these instructions or to maintain this product according to directions can cause soot production.

Long Term Storage

- Unscrew the Fuel Cap.
 - Using an approved kerosene siphon, remove kerosene.
 - Using a small amount of kerosene, rinse and swirl the kerosene inside of the Fuel Tank. Empty the tank fully.
 - NEVER MIX WATER WITH KEROSENE, as it will cause rust inside the tank.
 - Empty tank completely.
- Never store leftover kerosene over the summer. Using old fuel can damage your heater.**

Store heater in a dry, well-ventilated area

- Be sure that the storage area is free of dust and corrosive vapors. Repack the heater in the original shipping material. Keep the User's Manual in an easily accessible place.

NEVER LEAVE HEATER
UNATTENDED WHILE BURN-
ING, OR WHILE CONNECTED
TO A POWER SOURCE.



Ultra-Portable Oil-
Fired Radiant Heater

Exploded Drawing Part Breakdown

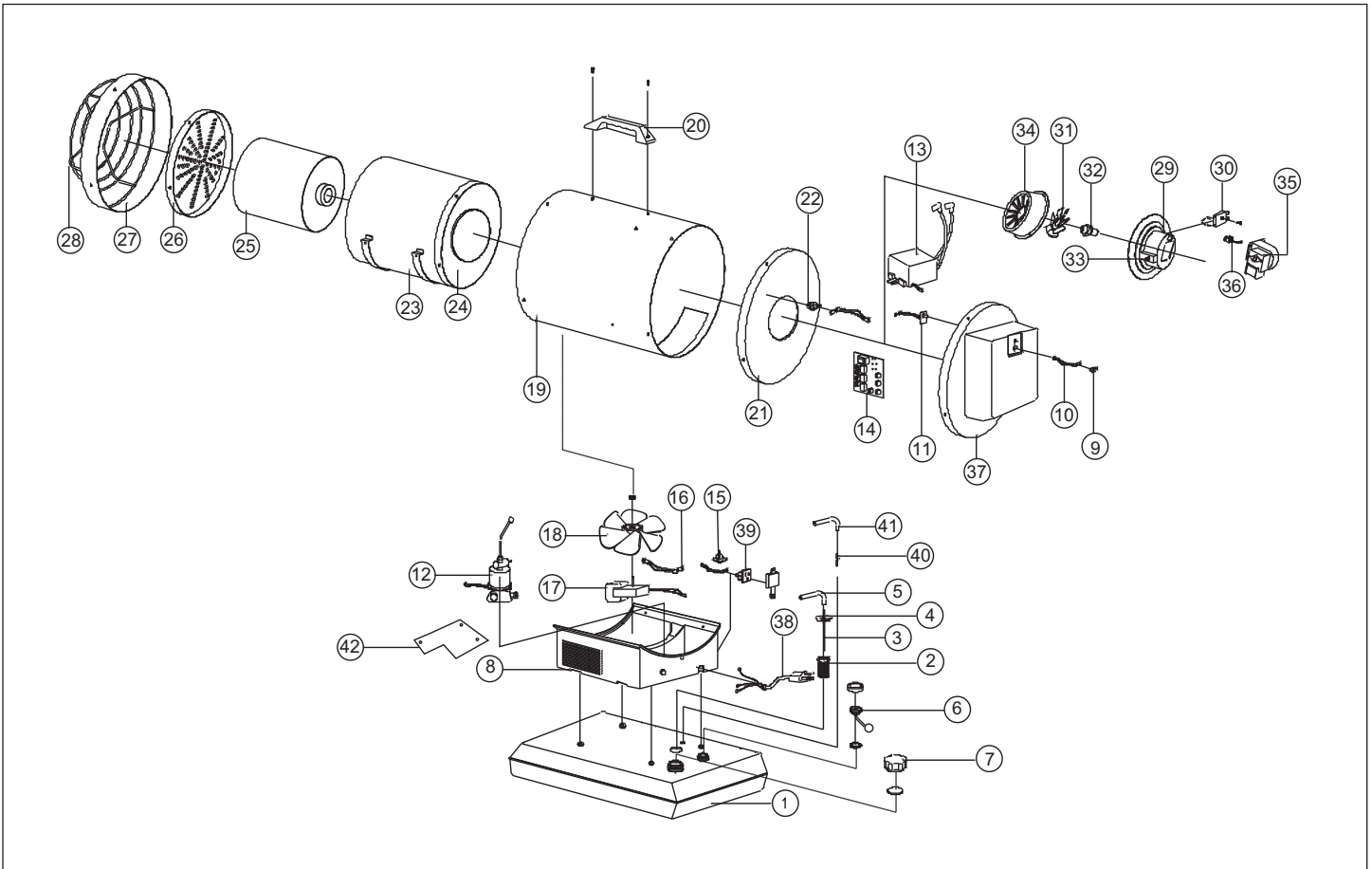

Figure 11. Exploded View: PT-70-SS-A

Replacement Parts

Item #	Description	PT-70-SS-A
1	FUEL TANK ASSEMBLY	75-001-0350
2	OIL FILTER ASSEMBLY	75-023-0270
3	FUEL PIPE	75-023-0345
4	FUEL PACKING	75-023-0355
5	FUEL HOSE	75-024-0510
6	FUEL GAUGE ASSEMBLY	75-022-0210
7	FUEL CAP ASSEMBLY	75-002-0110
8	COOLING FAN HOUSING	75-011-0670
9	OPERATING SWITCH	75-012-0110
10	OPERATING SWITCH WIRE ASSEMBLY	75-012-0220
11	REAR PCB ASSEMBLY	75-013-0200
12	ELECTRONIC-PUMP ASSEMBLY	75-027-0250

**NEVER LEAVE HEATER
UNATTENDED WHILE BURN-
ING, OR WHILE CONNECTED
TO A POWER SOURCE.**



**Ultra-Portable Oil-
Fired Radiant Heater**

Replacement Parts

Item #	Description	PT-70-SS-A
13	IGNITOR	75-025-0120
14	MAIN PCB ASSEMBLY	75-025-0400
15	TIP OVER SENSOR	75-051-0200
16	TIP OVER SENSOR WIRE ASSEMBLY	75-051-0260
17	COOLING MOTOR ASSEMBLY	75-047-0250
18	COOLING FAN	75-047-0200
19	SHELL	75-011-1000
20	HANDLE	75-001-0060
21	SHELL INSULATOR	75-011-1100
22	TEMPERATURE LIMIT(OVERHEAT) SWITCH	75-040-0100
23	CHAMBER ASSEMBLY	75-035-0800
24	CHAMBER INSULATOR	75-035-0820
25	CERAMIC FIBER	75-035-0830
26	HEAT PLATE	75-012-0600
27	SHELL-RING	75-011-0650
28	SAFETY GUARD	75-012-0310
29	BURNER BODY	75-036-0180
30	SPARK PLUG	75-075-0200
31	BURNER BLADE	75-036-0120
32	NOZZLE	75-036-0400
33	NIPPLE	75-040-0610
34	DIFFUSION CAP	75-036-0500
35	BLOWER MOTOR ASSEMBLY	75-045-0200
36	PHOTOCELL ASSEMBLY	75-038-0200
37	BACK COVER	75-013-0105
38	POWER CORD ASSEMBLY	75-032-0180
39	ELECTRICAL OUTLET ASSEMBLY	75-029-0100
40	RETURN PIPE	75-055-0100
41	RETURN HOSE	75-055-0200
42	ELECTRONIC-PUMP BRACKET	75-027-0255

NEVER LEAVE HEATER
UNATTENDED WHILE BURN-
ING, OR WHILE CONNECTED
TO A POWER SOURCE.



Ultra-Portable Oil-
Fired Radiant Heater

Wiring Diagrams

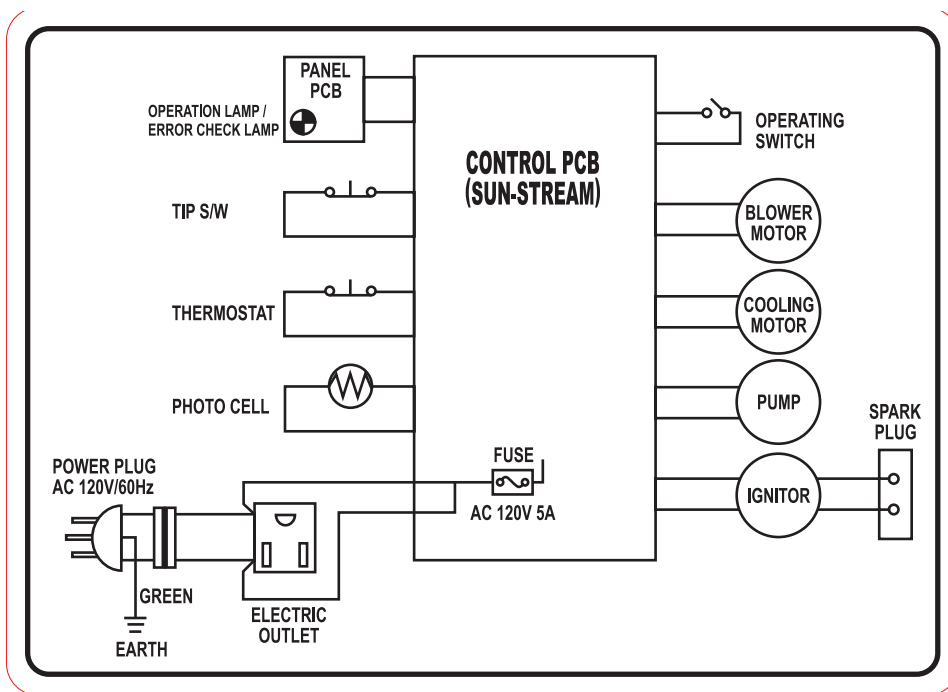

Figure 12. Wiring Diagram for model PT-70-SS-A
(subject to change without notice)

**NEVER LEAVE HEATER
UNATTENDED WHILE BURN-
ING, OR WHILE CONNECTED
TO A POWER SOURCE.**



**Ultra-Portable Oil-
Fired Radiant Heater**

Trouble Shooting Guide

Problem	Possible Cause	Solution
Heater fires, but shuts down after a short period of time.	<ol style="list-style-type: none"> 1. Dirty Fuel Filter. 2. Nozzle Dirty. 3. Photocell Dirty. 4. Photocell not installed properly. 5. Photocell Defective . 6. Improper electrical connection between Circuit Board and Photocell. 7. Cooling Fan is obstructed 	<ol style="list-style-type: none"> 1. Clean/replace Fuel Filter (Page 6). 2. Clean/replace Nozzle (Page 7). 3. Clean/replace Photocell (Page 7). 4. Adjust Photocell position. 5. Replace Photocell. 6. Check wiring connections (See Wiring Diagrams, Page 10). 7. Check to be sure cooling fan is not obstructed.
Heater will not operate, or motor runs for short time.	<ol style="list-style-type: none"> 1. No kerosene in fuel tank. 2. Corroded Spark Plug or incorrect plug gap. 3. Dirty Fuel Filter. 4. Dirty Nozzle. 5. Moisture in Fuel/Fuel Tank. 6. Improper electrical connection between Transformer and Circuit Board. 7. Transformer Wires not connected to Spark Plug. 8. Defective Transformer. 	<ol style="list-style-type: none"> 1. Fill tank with fresh kerosene. 2. Clean/replace Spark Plug (Page 7). 3. Clean/replace Fuel Filter (Page 6). 4. Clean/replace Nozzle (Page 7). 5. Rinse out fuel tank with clean fresh kerosene (Page 6). 6. Inspect all electrical connections. (See Wiring Diagrams, Page 10). 7. Re-attach Transformer wires to Spark Plug. 8. Replace Transformer.
Fan does not operate when heater is plugged in and Operating Switch is in the "ON" position.	<ol style="list-style-type: none"> 1. Broken electrical connection between Circuit Board and motor. 2. Not enough amps available to power heater. 	<ol style="list-style-type: none"> 1. Inspect all electrical connections on Wiring Diagrams (Page 10). 2. Use a new extension cord or try another electrical socket.
Heater makes grinding noise.	<ol style="list-style-type: none"> 1. Air in fuel pump. 	<ol style="list-style-type: none"> 1. Sound will stop after 3 seconds. If grinding sound continues, add fuel to tank.
Heater does not turn on and the lamp is not lit.	<ol style="list-style-type: none"> 1. Temperature limit sensor has over-heated. 2. No electrical power. 3. Fuse break down. 4. Improper electrical connection between Temperature Limit Sensor and Circuit Board. 	<ol style="list-style-type: none"> 1. Push Operating Switch to "OFF" and allow heater to cool for 5 minutes. Push Operating Switch back to "ON". 2. Check power cord and extension cord to insure of proper connection. Test power supply. 3. Check/replace Fuse. 4. Inspect all electrical connections. (See Wiring Diagrams, Page 10).
Poor combustion and / or soot production.	<ol style="list-style-type: none"> 1. Pump Pressure. 2. Poor fuel quality. 	<ol style="list-style-type: none"> 1. Be sure pump pressure is adjusted correctly. 2. Be sure kerosene is not old or contaminated.

NEVER LEAVE HEATER
UNATTENDED WHILE BURN-
ING, OR WHILE CONNECTED
TO A POWER SOURCE.



Ultra-Portable Oil-
Fired Radiant Heater

LIMITED 1-YEAR WARRANTY

Pinnacle Products International, Inc. warrants this heater to the original retail purchaser only, to be free from defects in material and workmanship for a period of one (1) year from the date of initial purchase. This product must be properly installed, maintained and operated in accordance with the instructions provided.

Pinnacle Products International, Inc. requires reasonable proof of your date of purchase from an authorized retailer or distributor. Therefore, you should keep your sales slip, invoice, or cancelled check from the original purchase. This Limited Warranty shall be limited to the repair or replacement of parts, which prove defective under normal use and service within the warranty period, and which **Pinnacle Products International, Inc.** shall determine at its reasonable discretion.

This warranty does not apply to products purchased for rental use.

This Limited Warranty does not cover any failures or operating difficulties due to normal wear and tear, accident, abuse, misuse, alteration, misapplication, improper installation or improper maintenance and service by you or any third party. Failure to perform normal and routine maintenance on the heater, shipping damage, damage related to insects, birds, or animals of any kind, and damage due to weather conditions are also not covered. In addition, the Limited Warranty does not cover damage to the finish, such as scratches, dents, discoloration, rust or other weather damage, after purchase.

All transportation costs for the return of the damaged product or parts will be the responsibility of the purchaser. Upon receipt of damaged item, **Pinnacle Products International, Inc.** will examine the item and determine if defective. **Pinnacle Products International, Inc.** will repair or replace and return the item, freight pre-paid. If **Pinnacle Products International, Inc.** finds the item to be in normal operating condition, or not defective, the item will be returned freight collect. This Limited Warranty is in lieu of all other express warranties. **Pinnacle Products International, Inc.** disclaims all warranties for products that are purchased from sellers other than authorized retailers or distributors.

AFTER THE PERIOD OF THE ONE (1) YEAR EXPRESS WARRANTY EXPIRES, **Pinnacle Products International, Inc.** DISCLAIMS ANY AND ALL IMPLIED WARRANTIES, INCLUDING WITHOUT LIMITATION THE IMPLIED WARRANTIES OF MERCHANTABILITY AND FITNESS FOR A PARTICULAR APPLICATION. FURTHER, **Pinnacle Products International, Inc.** SHALL HAVE NO LIABILITY WHATSOEVER TO PURCHASER OR ANY THIRD PARTY FOR ANY SPECIAL, INDIRECT, PUNITIVE, INCIDENTAL, OR CONSEQUENTIAL DAMAGES. **Pinnacle Products International, Inc.** assumes no responsibility for any defects caused by third parties. This Limited Warranty gives the purchaser specific legal rights; a purchaser may have other rights depending upon where he or she lives. Some states do not allow the exclusion or limitation of special, incidental or consequential damages, or limitations on how long a warranty lasts, so the above exclusion and limitations may not apply to you.

Pinnacle Products International, Inc. does not authorize any person or company to assume for it any other obligation or liability in connection with the sale, installation, use, removal, return, or replacement of its equipment, and no such representations are binding on **Pinnacle Products International, Inc.**

Always be sure to specify model number and serial number when making any claim with **Pinnacle Products International, Inc.** For your convenience use the space provided below to list this information:

Model #: _____

Serial #: _____

Date of Purchase: _____