

# Table of Contents

---

Coffee Maker Safety .....	3
Electrical Requirements .....	4
Coffee Maker Parts .....	5
Coffee Maker Features .....	6
Display And Control Pad Features .....	7
Coffee Brewing Suggestions: Advice For Great Taste .....	8
Preparing Your Coffee Maker For Use .....	8
Kitchenaid® Coffee Maker Use .....	10
Coffee Maker Enhanced Features .....	12
Pause And Pour Feature .....	12
Automatic Brew Timer .....	12
Using the Preprogrammed Automatic Brew Time Again .....	13
Brew Strength .....	13
Variable Warmth Control/Selectable Automatic Shutoff .....	13
Coffee Maker Care .....	14
Troubleshooting .....	15
Proof of Purchase and Product Registration.....	15
Warranty .....	16

# Coffee Maker Safety

## Your safety and the safety of others are very important.

We have provided many important safety messages in this manual and on your appliance. Always read and obey all safety messages.



This is the safety alert symbol.

This symbol alerts you to potential hazards that can kill or hurt you and others.

All safety messages will follow the safety alert symbol and either the word "DANGER" or "WARNING." These words mean:

**! DANGER**

**You can be killed or seriously injured if you don't immediately follow instructions.**

**! WARNING**

**You can be killed or seriously injured if you don't follow instructions.**

All safety messages will tell you what the potential hazard is, tell you how to reduce the chance of injury, and tell you what can happen if the instructions are not followed.

	<b>WARNING</b> RISK OF FIRE OR ELECTRIC SHOCK DO NOT OPEN	
<p>WARNING: TO REDUCE THE RISK OF FIRE OR ELECTRIC SHOCK, DO NOT REMOVE COVER (OR BACK). NO USER-SERVICEABLE PARTS INSIDE. REPAIR SHOULD BE DONE BY AUTHORIZED SERVICE PERSONNEL ONLY.</p>		

## IMPORTANT SAFEGUARDS

When using electrical appliances, basic safety precautions should always be followed, including the following:

1. Read all instructions.
2. Do not touch hot surfaces. Use handles or knobs.
3. To protect against electrical shock, do not immerse cord, plugs, or coffee maker in water or other liquid.
4. Close supervision is necessary when any appliance is used by or near children.
5. Unplug coffee maker from outlet when not in use and before cleaning. Allow to cool before putting on or taking off parts.
6. Do not operate any appliance with a damaged cord or plug or after the appliance malfunctions or has been damaged in any manner. Return appliance to the nearest Authorized Service Facility for examination, repair or adjustment.
7. The use of accessory attachments not recommended by the appliance manufacturer may cause injuries.
8. Do not use outdoors.
9. Do not let cord hang over edge of table or counter, or touch hot surfaces.
10. Do not place on or near a hot gas or electric burner, or in a heated oven.
11. Do not use appliance for other than intended use.

12. Do not use appliance without lid properly placed on container (carafe).
13. The container (carafe) is designed for use with this appliance. It must never be used on a range top or in a microwave oven.
14. Do not set a hot container (carafe) on a wet or cold surface.
15. Do not use a cracked container (carafe) or a container having a loose or weakened handle.
16. Do not clean container with abrasive cleaners, steel wool pads, or other abrasive material.
17. This product is designed for household use only.

# SAVE THESE INSTRUCTIONS

## Electrical Requirements

### **! WARNING**



#### **Electrical Shock Hazard**

**Plug into a grounded 3 prong outlet.**

**Do not remove ground prong.**

**Do not use an adapter.**

**Do not use an extension cord.**

**Failure to follow these instructions can result in death, fire, or electrical shock.**

Do not use an extension cord. If the power supply cord is too short, have a qualified electrician or serviceman install an outlet near the appliance.

A short power supply cord (or detachable power supply cord) should be used to reduce the risk resulting from becoming entangled in or tripping over a longer cord.

If a longer detachable power supply cord or extension cord is used:

- The marked electrical rating of the cord set or extension cord should be at least as great as the electrical rating of the appliance.
- The cord should be arranged so that it will not drape over the countertop or tabletop where it can be pulled on by children or tripped over unintentionally.

If the appliance is of the grounded type, the extension cord should be a grounding-type 3-wire cord.

Volts: 120 Volts AC only

Hertz: 60 Hz

**NOTE:** This coffee maker has a 3-prong grounded plug. To reduce the risk of electrical shock, this plug will fit in an outlet only one way. If the plug does not fit in the outlet, contact a qualified electrician. Do not modify the plug in any way.

# Coffee Maker Parts

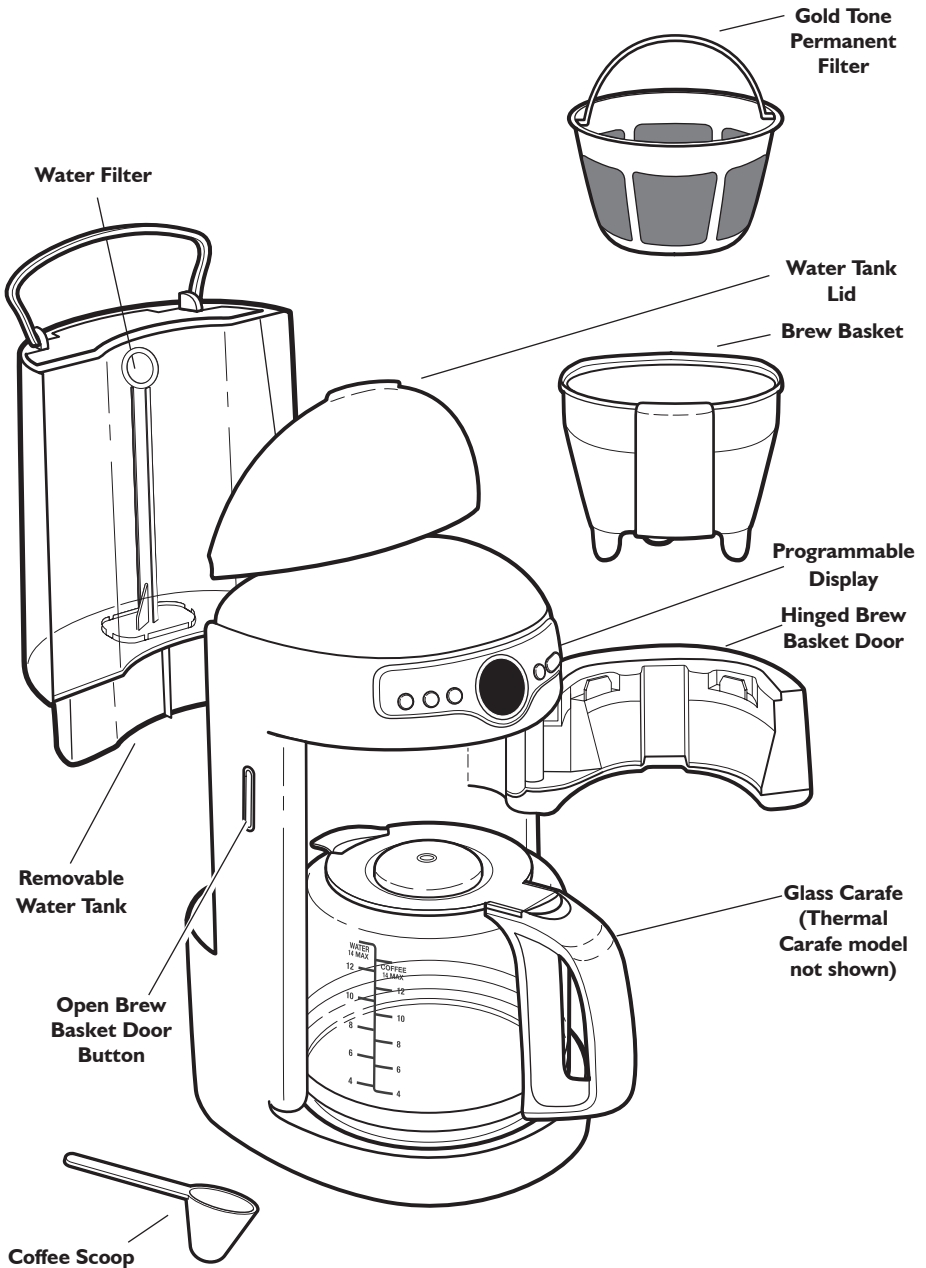

# Coffee Maker Features

---

## **1-4 Cup Feature**

This feature ensures optimum flavor even when you're not brewing a full pot.

## **Clean Alert and Clean Feature**

The Clean Alert indicator reminds you when the coffee maker needs to be cleaned. The Clean Mode can then be activated to descale your coffee maker.

## **Pause and Pour Feature**

Pause and pour lets you remove the carafe and pour a cup of coffee before brewing is finished. A special valve seals the brew basket tightly, eliminating most drips.

## **End-Of-Brewing Tone**

A tone sounds when coffee is finished brewing.

## **Selectable Automatic Shutoff**

This feature allows you to select automatic shutoff times from 0.5-4 hours in 30-minute increments.

## **Brew Basket Door**

Access the removable brew basket by pressing the button on the side of the coffee maker. The spring loaded door includes a latch to assure the door is closed completely.

## **Brew Basket**

The brew basket holds paper coffee filters or the Gold Tone permanent filter. The brew basket can be washed in the top rack of a dishwasher.

## **Removable Water Tank**

The coffee maker features a convenient removable water tank with water level indicators. Remove the tank and add water directly to the water tank or lift the lid to add water. It is recommended that the tank be hand washed.

## **Automatic Brew Timer**

An easy to set 24 hour brew timer will brew coffee at the selected time, day or night.

## **Variable Warmth Control (on glass carafe models only)**

Allows you to select High, Medium, or Low settings for the carafe heating plate. The Variable Warmth Control is programmable from 0.5-4 hours in

30-minute increments. After the brew process is complete, the time since brewed will be displayed in 1-minute increments.

## **Glass or Thermal Carafe**

The 14-cup glass and 12-cup thermal carafes feature a dripless pouring spout and comfortable soft grip handle. Both carafes can be washed in the top rack of a dishwasher.

## **Gold Tone Permanent Filter**

The high-performance Gold Tone filter eliminates the need for paper coffee filters. Coffee maker can also use paper filters, if desired. The Gold Tone Filter can be washed in the top rack of a dishwasher.

## **Water Filter**

The replaceable carbon filter can be found at your local retailer or on [www.KitchenAid.com](http://www.KitchenAid.com).

## **Coffee Scoop**

Use one level scoop of ground coffee for each cup desired.

## **Power Interrupt**

If the power is interrupted for less than 1 minute, the coffee maker will remember the preprogrammed settings.

## **Clock Display**

Displays the time of day with AM and PM indicators. The energy saving sleep mode feature dims the clock display when the coffee maker is not in use.

## **Variable Brew Strength Selector**

Allows you to select between REG and BOLD brew strengths.

## **Full-Length Cord Storage (not shown)**

Compartment in the back of the coffee maker keeps excess cord out of the way.

## **Heat Pump (not shown)**

Powerful heat pump brews rich, flavorful coffee.

## **Electronic Temperature Control**

Electronic temperature control regulates the powerful 1100-watt heat pump to ensure consistent brewing every time.

# Display and Control Pad Features

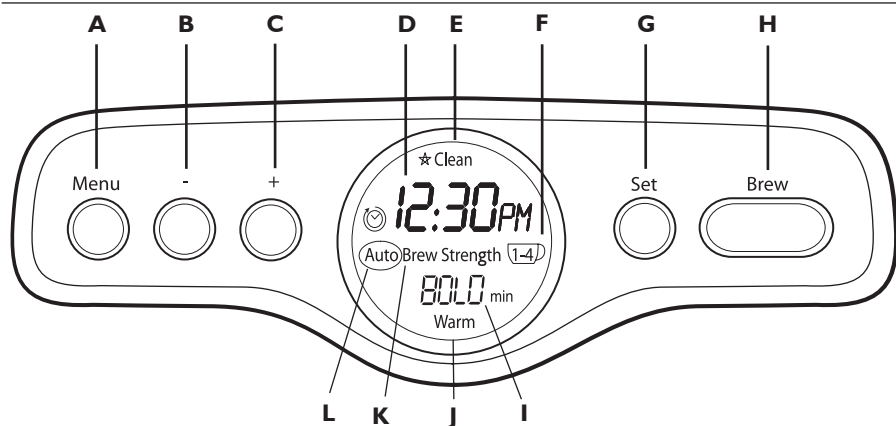

A. Menu Button

B. “-” (minus) Button

C. “+” (plus) Button

D. Clock Display

E. Cleaning Needed Indicator

F. 1-4 cup Indicator

G. Set Button

H. Brew Button

I. Mode Selection/Brew Strength/Time Since Brewed Display area

J. Warm Indicator

K. Brew Strength Indicator

L. Auto indicator

## DISPLAY FEATURES:

### Clock Display (D)

Shows the time-of-day with AM or PM indicator and automatic brew time.

### Cleaning Needed Indicator (E)

The indicator will light after brewing if the coffee maker requires descaling.

### 1-4 Cup Indicator (F)

This special cycle ensures optimum flavor when brewing small pots of coffee. An indicator light shows when the 1-4 cup brew cycle is activated.

### Time Since Brewed Display (I) (glass carafe models only)

Display shows the time elapsed since the completion of the brewing cycle. Time will be displayed in minutes up to the maximum of 240 minutes. The display will alternate between “Time Since Brew” and the temperature (HIGH, MED, or LOW).

### Warm Indicator (J)

Display is on when in the “Warm” mode.

### Brew Strength Indicator (K)

Indicates brew strength (REG or BOLD).

### Auto Indicator (L)

Display is on when in “Automatic Brew” mode.

## CONTROL PAD FEATURES:

### Menu Button (A)

Press to select the desired program.

### “+” (plus) and “-” (minus) Buttons (B,C)

Use the “+” (plus) and “-” (minus) buttons to program the coffee maker features.

### Set Button (G)

Press to enter program selections.

### Brew Button (H)

Press to start the selected brew cycle.

# Coffee Brewing Suggestions: Advice For Great Taste

---

## **Fresh Coffee Beans**

Truly great coffee can only come from fresh coffee beans. To preserve the freshness of your beans, keep the beans in an opaque, airtight container and store them in a cool, dry place. Refrigeration is not recommended since condensation tends to form on the beans whenever the container is opened. Freezing can help preserve beans stored for an extended period, but it will also impair flavor.

## **The Right Grind**

The best cup of coffee comes from coffee beans that are properly ground just before brewing. When grinding, be sure to grind your coffee to a medium grind level, the appropriate grind for automatic drip coffee makers.

Look for the KitchenAid® blade or burr coffee grinders at your local retailer or online at [www.KitchenAid.com](http://www.KitchenAid.com).

## **The Proper Amount of Ground Coffee**

A good starting point is one scoop of coffee (scoop provided) for every cup of brew water marked on the glass carafe or the water tank. Finer grinds usually require less coffee but may also produce bitterness and clog the filter.

For weaker coffee, brew using the suggested ratio of coffee grounds and water, then dilute with hot water. This maximizes flavor and minimizes bitterness.

## **Brew Water Purity**

Great tasting coffee starts with fresh water. The removable water tank is easy to fill with water to give you great tasting coffee every time. It's also easy to clean so you can always make your coffee with the freshest water. Using the included water filter is also recommended.

Where local water is extremely poor, you may wish to use bottled water. Do not use distilled water or mineral water since they can damage your coffee maker.

## **Coffee Maker Cleanliness**

Since the coffee oils that build up on the brew basket and carafe can go stale and impair the flavor of the brewed coffee, it's important that these two items are cleaned daily in order to make the best tasting coffee.

# Preparing Your Coffee Maker For Use

---

## **Pre-Use Cleaning**

Wash the brew basket, Gold Tone permanent filter, and carafe in hot, soapy water, then rinse with clean water and dry. Do not use abrasive cleansers or scouring pads.

## **Installing the Water Filter**

Use of the water filter is strongly recommended. Use of the filter is optional. The coffee maker will operate normally without it.

1. The filter consists of a long handle with a filter cartridge at the end.
2. Place the filter cartridge in a separate container filled with fresh, cool water. The cartridge should remain submerged in the water for 10 minutes. Rinse the filter under running water for 2 seconds after soaking.
3. Lift the water tank lid using the tab on the rear of the lid.

- Place the filter cartridge in the well at the bottom of the water tank. Push the cartridge slightly to make sure it fits snugly.

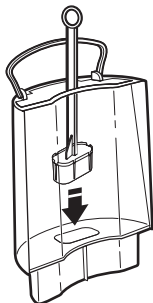

- Every time you install a new filter, run the coffee maker through a complete brewing cycle without coffee. Use a full carafe of clean, cool water. See “Coffee Maker Care” for information on when to change the water filter.

### To Set the Time-of-Day Clock for the First Time or After Power Outage

## **! WARNING**



### **Electrical Shock Hazard**

**Plug into a grounded 3 prong outlet.**

**Do not remove ground prong.**

**Do not use an adapter.**

**Do not use an extension cord.**

**Failure to follow these instructions can result in death, fire, or electrical shock.**

- Plug into a grounded 3-prong outlet.
- When the coffee maker is first plugged in or when power is restored after an interruption, the brew timer display will initially show 12:00 AM, with the hours section flashing “12”. The Clock indicator will flash while the time is being set.

- Press the “+” (plus) or “-” (minus) buttons to increase or decrease the hours.
- Press the SET button. The minutes digits will flash for the minutes adjustment.
- Press the “+” (plus) or “-” (minus) buttons to increase or decrease the minutes.
- Press the SET button again The AM or PM indicator will flash for the AM/PM adjustment.
- Press the “+” (plus) or “-” (minus) buttons to select AM or PM.
- Press SET button to choose the selected time. Two short beeps will sound indicating programming is complete.

### To Set the Time-of-Day Clock

When the coffee maker is first plugged in, or after a power interruption of more than one minute, the coffee maker will power up in the clock setting mode. In this case, follow the previous directions “To Set the Time-of-Day Clock for the First Time or After Power Outage”. If adjusting the time of the clock after initial set up, follow the complete instructions below.

- For glass carafe models, press the MENU button 6 times to enter the Time/Clock Setting mode. The Clock indicator will flash while the time is being set.

**NOTE:** For thermal carafe models, press the MENU button 5 times to enter the Time/Clock Setting mode.

- Press the “+” (plus) or “-” (minus) buttons to increase or decrease the hours.
- Press the SET button. The minutes digits will flash for the minutes adjustment.
- Press the “+” (plus) or “-” (minus) buttons to increase or decrease the minutes.
- Press the SET button again The AM or PM indicator will flash for the AM/PM adjustment.
- Press the “+” (plus) or “-” (minus) buttons to select AM or PM.
- Press SET button to choose the selected time. Two short beeps will sound indicating programming is complete.



# KitchenAid® Coffee Maker Use

## Brewing Coffee

**NOTE:** Brew one pot of fresh, cool water and discard before brewing the first pot of coffee (first time use only).

1. Remove the water tank and fill with enough fresh, cool water to make the desired amount of coffee. A graduated scale on the tank measures the amount of water needed. When replacing the tank, make sure to align it with the tab(s).

**NOTE:** The tank can be filled using the carafe without removing the tank from the coffee maker.

The right side of the scale (“coffee”) is a measurement of coffee volume. The left side of the scale (“water”) is based upon 140 mL cups.

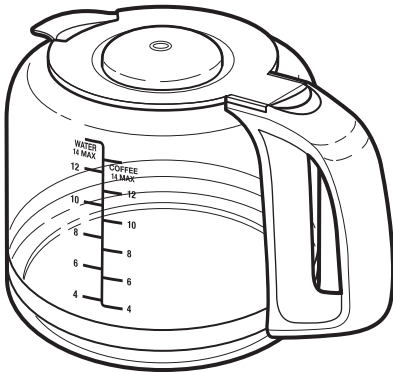

2. After filling the water tank, place the carafe in the coffee maker.

**IMPORTANT:** Make sure the lid is securely in position (For thermal carafe models, see “Placing the Lid on the Thermal Carafe”) and the bottom of the carafe is fully seated. If the carafe is not seated, the Pause and Pour feature may not engage and may cause water and coffee to overflow the brew basket.

To maximize coffee temperature, it is recommend that you fill and empty the carafe with hot water to preheat the carafe.

3. Open the brew basket door. Brew basket may be removed, but can be filled without removing it from the front of the coffee maker.

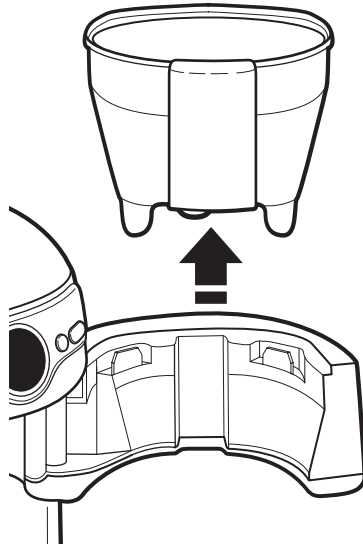

4. Insert a 12-14 cup flat bottom paper filter or the Gold Tone permanent filter into the brew basket.

**IMPORTANT:** Do not use both types of filters at the same time. Using both filters might cause water and coffee to overflow the brew basket.



5. Use the included scoop and fill the filter with one level scoop of ground coffee for each cup desired. Use a medium grind appropriate for automatic drip coffee makers.

**IMPORTANT:** Too fine a grind produces bitterness and may clog the coffee filter.

**NOTE:** Always place the filter and coffee into the removable brew basket. Do not operate the coffee maker without the brew basket in place.

6. Even out the bed of coffee with scoop. If the brew basket is removed, place the mounting holes over the pins in the door and seat it securely in the door. Be sure the brew basket door is fully closed before brewing.

### Brewing 4+ Cups of Coffee

1. Press the BREW button to begin brewing coffee.
2. For glass carafes only, the coffee maker will sound the end-of-brewing tone and the “Warm” indicator will turn on when brewing is complete.
3. For glass carafes only, the Time Since Brew display will alternate between the temperature setting (HIGH, MED, or LOW) and the time elapsed since the completion of the brewing cycle.
4. For glass carafes only, at the end of programmed Keep Warm Time (the default is 2 hours), the coffee maker will automatically shut off. To turn off the coffee maker manually, press the BREW button.

**NOTE:** The outside of the carafe will be hot to the touch after brewing. Use discretion when placing the carafe on uncovered surfaces immediately after brewing.

5. Repeat the procedure in the “Brewing Coffee” and “Brewing 4+ Cups of Coffee” sections to brew additional carafes of coffee. Always turn off the coffee maker and allow it to cool for 5 minutes before starting the next brew cycle.

### Brewing 1-4 Cups of Coffee

**NOTE:** Brew one pot of fresh, cool water and discard before brewing the first pot of coffee (first time use only).

1. Repeat steps 1-5 in the “Brewing Coffee” section.
2. Press the MENU button 3 times to enter the 1-4 Cups mode. The “1-4” indicator will show and “OFF” indicator will flash.
3. Press the “+” (plus) or “-” (minus) buttons until ON is displayed.
4. Press the SET button to select the 1-4 Cups mode. Two short beeps will sound indicating programming is complete.
5. Press the BREW button to begin brewing coffee.
6. The coffee maker will sound the end-of-brewing tone when brewing is complete.
7. On glass carafe models only, the Time Since Brew display indicates the time elapsed since the completion of the brewing cycle. At the end of programmed Keep Warm Time (the default is 2 hours), the coffee maker will automatically shut off. To turn off the coffee maker manually, press the BREW button.  
**NOTE:** The outside of the carafe will be hot to the touch after brewing. Use discretion when placing the carafe on uncovered surfaces immediately after brewing.
8. Repeat the procedure in the “Brewing Coffee” and “Brewing 1-4 Cups of Coffee” sections to brew additional carafes of coffee. Always turn off the coffee maker and allow it to cool for 5 minutes before starting the next brew cycle.

## Placing the Lid on the Thermal Carafe

To properly place the lid on the thermal carafe, follow these instructions.

1. Place the lid onto the thermal carafe with the thumb lever to the right of the handle.

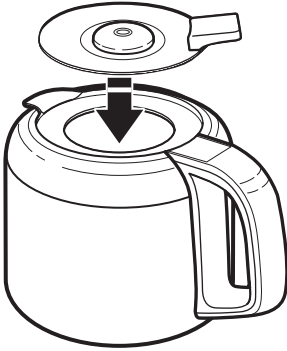

2. Rotate the lid counterclockwise until the thumb lever is over the handle.

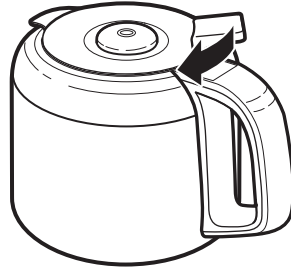

3. To pour, press the thumb lever down.

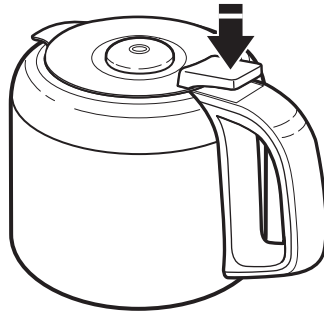

## Coffee Maker Enhanced Features

### Pause and Pour Feature

The Pause and Pour feature enables you to remove the carafe from the coffee maker and pour a cup of coffee before brewing is finished. When the carafe is removed, a special valve stops the flow of coffee from the brew basket. However, brewing does not stop. If the carafe is not placed back in the coffee maker within 25 seconds, water and coffee will overflow the brew basket.

### Automatic Brew Timer

The coffee maker can be programmed to brew coffee at a preset time, making it easy to wake up to fresh coffee every morning.

To program and activate the Automatic Brew Timer:

1. Press the MENU button 1 time to enter the "Auto Brew Timer" mode. The "Auto" and "OFF" indicators will flash. Press the "+" (plus) or "-" (minus) button to select "ON". Press the SET button.

2. The hours digits will flash next. Press the "+" (plus) or "-" (minus) button to set the hour. Press the SET button.
3. The minutes digits will flash next. Press the "+" (plus) or "-" (minus) button to set the minutes. Press the SET button.
4. The "AM/PM" indicators will flash next. Press the "+" (plus) or "-" (minus) button to select AM or PM. Two short beeps will sound indicating programming is complete.
5. The "Auto" indicator will turn on and the coffee maker will begin brewing at the programmed time. The time that is set will be displayed for 3 seconds as a reminder of the set time. The programmed time will remain active until steps 1-4 are repeated or power is interrupted for more than 60 seconds.

**NOTE:** To turn off the Automatic Brew settings, return to the Automatic Brew function on the menu and select "OFF".

## Using the Programmed Automatic Brew Time Again

After setting up your Automatic Brew Time, you can use the following directions to reuse your previously programmed time setting.

To re-activate the Programmed Automatic Brew Time:

1. Press the MENU button 1 time to enter the "Auto Brew Timer" mode. The "Auto" and "OFF" indicators will flash. Press the "+" (plus) or "-" (minus) button to select "ON". Press the SET button.
2. The hours digits will flash next. Press the SET button to set the hour.
3. The minutes digits will flash next. Press the SET button to set the minutes.
4. The "AM/PM" indicators will flash next. Press the SET to select AM or PM. Two short beeps will sound indicating programming is complete.
5. The "Auto" indicator will turn on and the coffee maker will begin brewing at the programmed time. The time that is set will be displayed for 3 seconds as a reminder of the set time. The programmed time will remain active until steps 1-4 are repeated or power is interrupted for more than 60 seconds.

**NOTE:** To reactivate the programmed time, press and hold the BREW button. The "Auto" indicator will turn on and the coffee maker will begin brewing at the programmed time.

## Brew Strength

The coffee maker can be programmed to brew coffee at regular (REG) or bold (BOLD) strengths.

**NOTE:** If you do not complete the programming steps within 10 seconds, the settings will be maintained and the coffee maker will exit to the default mode.

To program and activate the Brew Strength:

1. Press the MENU button 2 times to enter the "Brew Strength" mode. The "Brew Strength" indicator will flash until this programming cycle is complete.

2. The strength (REG or BOLD) indicator will flash. Press the "+" (plus) or "-" (minus) button to select the brew strength desired (REG or BOLD).
3. Press the SET button to program the Brew Strength setting. Two short beeps will sound, indicating programming is complete. The programmed strength will remain active until steps 1-3 are repeated or power is interrupted for more than 60 seconds.

## Variable Warmth Control/Selectable Automatic Shutoff

For glass carafe models only, the coffee maker can be programmed to keep coffee warm for a specific length of time and temperature. This feature is not available on thermal carafe models.

**NOTE:** If you do not complete the programming steps within 10 seconds, the settings will be maintained and the coffee maker will exit to the Default mode.

To program and activate the Warm Timer/ Temperature setting:

1. Press the MENU button 4 times to enter the "Warm Timer / Temperature" mode. The "Warm" indicator and time digits will flash until this programming cycle is complete.
2. Press the "+" (plus) or "-" (minus) button to select the length of warm time desired. The time range can be selected between 0.5 and 4 hours in 30-minute increments.
3. Press the SET button. The "Warm" indicator and temperature setting (LOW, MED, or HIGH) will flash. Press the "+" (plus) or "-" (minus) button to select the temperature (LOW, MED, or HIGH).
4. Press the SET button to program the Warm Timer/ Temperature setting. Two short beeps will sound, indicating programming is complete. The programmed temperature will remain active until steps 1-4 are repeated or power is interrupted for more than 60 seconds.

# Coffee Maker Care

---

## Cleaning the Coffee Maker

1. Remove the brew basket and carafe from the coffee maker.
2. Wash the brew basket and Gold Tone permanent filter in hot, soapy water and rinse with hot water. Do not use abrasive cleansers or scouring pads. These parts can also be washed in the upper rack of a dishwasher.
3. Unplug the coffee maker and wipe the housing with a warm, soapy cloth. Then wipe clean with damp cloth and dry with a soft cloth. Do not use abrasive cleansers or scouring pads.

## Cleaning Needed Indicator

Calcium deposits (scale) from water will build up in the coffee maker heat pump over time and impair brewing efficiency and coffee quality. When the coffee maker needs to be cleaned, the “Clean” indicator will flash after a brewing cycle is complete. Once this occurs, descaling should be done as soon as possible to preserve the performance and life of your coffee maker.

**NOTE:** You may want to clean your coffee maker prior to the “Cleaning Needed” indicator flashing under heavy use or hard water conditions.

## Descaling the Coffee Maker

The coffee maker can be descaled using a packaged descaling agent or vinegar. Always mix the descaling solution using cool water.

- When using a descaling agent, follow the directions on the package for the recommended amounts of descaling agent and water to use.
  - When using vinegar, fill the carafe with a solution consisting of  $\frac{1}{2}$  vinegar and  $\frac{1}{2}$  water.
1. Before descaling, always remove the water filter (see the “Installing the Water Filter” section) and make sure the brew basket contains no coffee or coffee filters.
  2. Run the coffee maker through a complete Clean cycle using a full tank of the descaling solution.

**NOTE:** If you do not complete the programming steps within 10 seconds, the settings will be maintained and the coffee maker will exit to the default mode.
  3. For glass carafe models, press the MENU button 5 times to enter the Clean mode. The “Clean” and “ON” indicators will flash.

**NOTE:** For thermal carafe models, press the MENU button 4 times to enter the Clean mode. The “Clean” and “ON” indicators will flash.
  5. Press the SET button to program the Clean setting. Two short beeps will sound, indicating programming is complete.
  6. Press the BREW button to start the cleaning cycle. Once the cleaning cycle is complete, the “Clean” indicator will turn off.
  7. Rinse the coffee maker by running it through 2 brewing cycles using a full water tank of fresh, cool water each time.
  8. Wash the brew basket in hot, soapy water and rinse with hot water. The brew basket can also be washed in the upper rack of the dishwasher.
  9. Reinstall or replace the water filter. Replace the filter every 3 months under normal use. Replace it more often under heavy use or hard water conditions. The replaceable carbon filter can be found at your local retailer or on [www.KitchenAid.com](http://www.KitchenAid.com).

# Troubleshooting

---

- **If the brew timer display is not illuminated:**

Check to see whether the coffee maker is plugged into a grounded 3-prong outlet. If it is, check the fuse or circuit breaker on the electrical circuit the coffee maker is connected to and make sure the circuit is closed.

- **If only a portion of the water added to the coffee maker actually brews:**

The coffee maker requires immediate descaling. Please refer to “Descaling the Coffee Maker” in the “Coffee Maker Care” section.

- **If the problem cannot be corrected:**

See the KitchenAid warranty section. Do not return the coffee maker to the retailer; retailers do not provide service.

## Proof of Purchase and Product Registration

---

Always keep a copy of the sales receipt showing the date of purchase of your coffee maker. Proof of purchase will assure you of in-warranty service.

Before you use your coffee maker, please fill out and mail your product registration card packed with the unit. This card will enable us to contact you in the unlikely event of a product safety notification and assist us in complying with the provisions of the Consumer Product Safety Act. This card does not verify your warranty.

Please complete the following for your personal records:

**Model Number** \_\_\_\_\_

**Serial Number** \_\_\_\_\_

**Date Purchased** \_\_\_\_\_

**Store Name and Location** \_\_\_\_\_

## KitchenAid® Coffee Maker Warranty for the 50 United States, the District of Columbia, Puerto Rico, and Canada

This warranty extends to the purchaser and any succeeding owner for Coffee Makers operated in the 50 United States, the District of Columbia, Puerto Rico, and Canada.

<b>Length of Warranty:</b>	One Year Full Warranty from date of purchase.
<b>KitchenAid Will Pay for Your Choice of:</b>	<p>Hassle-Free Replacement of your Coffee Maker. See the next page for details on how to arrange for service, or call the Customer eXperience Center toll-free at <b>1-800-541-6390</b>.</p> <p>OR</p> <p>The replacement parts and repair labor costs to correct defects in materials and workmanship. Service must be provided by an Authorized KitchenAid Service Center.</p>
<b>KitchenAid Will Not Pay for:</b>	<ul style="list-style-type: none"> <li><b>A.</b> Repairs when Coffee Maker is used in other than normal single family home use.</li> <li><b>B.</b> Damage resulting from accident, alteration, misuse or abuse.</li> <li><b>C.</b> Any shipping or handling costs to deliver your Coffee Maker to an Authorized Service Center.</li> <li><b>D.</b> Replacement parts or repair labor costs for Coffee Makers operated outside the 50 United States, District of Columbia, Puerto Rico, and Canada.</li> </ul>
<p><b>DISCLAIMER OF IMPLIED WARRANTIES; LIMITATION OF REMEDIES</b></p> <p>IMPLIED WARRANTIES, INCLUDING TO THE EXTENT APPLICABLE WARRANTIES OF MERCHANTABILITY OR FITNESS FOR A PARTICULAR PURPOSE, ARE EXCLUDED TO THE EXTENT LEGALLY PERMISSIBLE. ANY IMPLIED WARRANTIES THAT MAY BE IMPOSED BY LAW ARE LIMITED TO ONE YEAR, OR THE SHORTEST PERIOD ALLOWED BY LAW. SOME STATES AND PROVINCES DO NOT ALLOW LIMITATIONS OR EXCLUSIONS ON HOW LONG AN IMPLIED WARRANTY OF MERCHANTABILITY OR FITNESS LASTS, SO THE ABOVE LIMITATIONS OR EXCLUSIONS MAY NOT APPLY TO YOU.</p> <p>IF THIS PRODUCT FAILS TO WORK AS WARRANTED, CUSTOMER'S SOLE AND EXCLUSIVE REMEDY SHALL BE REPAIR OR REPLACEMENT ACCORDING TO THE TERMS OF THIS LIMITED WARRANTY. KITCHENAID AND KITCHENAID CANADA DO NOT ASSUME ANY RESPONSIBILITY FOR INCIDENTAL OR CONSEQUENTIAL DAMAGES. This warranty gives you specific legal rights and you may also have other rights which vary from state to state or province to province.</p>	



## Hassle-Free Replacement Warranty – 50 United States, District of Columbia, and Puerto Rico

---

We're so confident the quality of our products meets the exacting standards of KitchenAid that, if your Coffee Maker should fail within the first year of ownership, KitchenAid will arrange to deliver an identical or comparable replacement to your door free of charge and arrange to have your original Coffee Maker returned to us. Your replacement unit will also be covered by our one year limited warranty. Please follow these instructions to receive this quality service.

If your Coffee Maker should fail within the first year of ownership, simply call our

toll-free Customer eXperience Center at **1-800-541-6390** Monday through Friday. Please have your original sales receipt available when you call. Proof of purchase will be required to initiate the claim. Give the consultant your complete shipping address. (No P.O. Box numbers, please.)

When you receive your replacement Coffee Maker, use the carton and packing materials to pack up your original Coffee Maker. In the carton, include your name and address on a sheet of paper along with a copy of the proof of purchase (register receipt, credit card slip, etc.).

## Hassle-Free Replacement Warranty – Canada

---

We're so confident the quality of our products meets the exacting standards of the KitchenAid® brand that, if your Coffee Maker should fail within the first year of ownership, KitchenAid Canada will replace your Coffee Maker with an identical or comparable replacement. Your replacement unit will also be covered by our one year limited warranty. Please follow these instructions to receive this quality service.

If your Coffee Maker should fail within the first year of ownership, take the Coffee Maker or ship collect to an Authorized KitchenAid Service Centre. In the carton

include your name and complete shipping address along with a copy of the proof of purchase (register receipt, credit card slip, etc.). Your replacement Coffee Maker will be returned prepaid and insured. If you are unable to obtain satisfactory service in this manner call our toll-free Customer eXperience Centre at **1-800-807-6777**.

Or write to us at:  
Customer eXperience Centre  
KitchenAid Canada  
200 - 6750 Century Ave.  
Mississauga, ON L5N 0B7

## Arranging for Service after the Warranty Expires, or Ordering Accessories and Replacement Parts

---

### In the United States and Puerto Rico:

For service information, or to order accessories or replacement parts, call toll-free at **1-800-541-6390** or write to:  
Customer eXperience Center,  
KitchenAid Portable Appliances,  
P.O. Box 218, St. Joseph, MI 49085-0218

### Outside the United States and Puerto Rico:

Consult your local KitchenAid dealer or the store where you purchased the Coffee Maker for information on how to obtain service.

### For service information in Canada:

Call toll-free **1-800-807-6777**.

Or write to:  
Customer eXperience Centre  
KitchenAid Canada  
200 - 6750 Century Ave.  
Mississauga, ON L5N 0B7