

LIMITED WARRANTY - RESIDENTIAL SUMP PUMPS:

Decko Products warrants that the products specified in this warranty are free from defects in material or workmanship for two years from date of purchase. During the time period and subject to the terms and conditions, Decko Products will repair or replace to the original user or consumer any portion of this product which proves to be defective due to materials or workmanship. At all times Decko Products shall have and possess the sole right and option to determine whether to repair or replace defective equipment, parts, or components. Decko Products has the option to inspect any product returned under warranty to confirm that the warranty applies before repair or replacement under warranty is approved. This warranty sets forth Decko Products sole obligation and purchaser's exclusive remedy for defective product. Return defective product to the place of purchase or postpaid to Decko Products, Attn: Warranty Dept., 2301 Traffic Street N.E., Minneapolis, MN 55413 for warranty consideration.

WARRANTY PERIOD - PRODUCTS:

If, within the duration of product use by the original user, this product proves to be defective due to materials or workmanship, the product shall be repaired or replaced at Decko Products option, subject to the terms and conditions set forth in this warranty statement. Proof of purchase is required for warranty consideration. In the absence of suitable proof of the purchase date, the effective period of this warranty is 12 months from the product's date of manufacture.

LABOR, ETC. COSTS:

Decko Products shall IN NO EVENT be responsible or liable for the cost of field labor or other charges incurred by any customer in removing and/or affixing any product, part, or component thereof.

PRODUCT IMPROVEMENTS:

Decko Products reserves the right to change or improve its products or any portions thereof without being obligated to provide such a change or improvement for units sold and/or shipped prior to such change or improvement.

GENERAL TERMS AND CONDITIONS:

This warranty shall not apply to damage due to acts of God, normal wear and tear, normal maintenance services and the parts used in connection with such service, lightning or conditions beyond the control of Decko Products, nor shall it apply to products which, in the sole judgment of Decko Products, have been subject to negligence, abuse, accident, misapplication, tampering, alteration; nor due to improper installation, operation, maintenance or storage; nor to excess of recommended maximums as set forth in the instructions. Warranty will be VOID if any of the following conditions are found:

1. Product is used for purposes other than those for which it was designed and manufactured
2. Product not installed in accordance with applicable codes, ordinances, and good trade practices
3. Product connected to voltage other than indicated on nameplate
4. Pump exposed to but not limited to the following: sand, gravel, cement, grease, plaster, mud, tar, oil, gasoline, solvents or other abrasive or corrosive substances
5. Pump has been used for pumping liquids above 120°F
6. Pump allowed to operate dry (liquid supply cut off)

DISCLAIMER:

Any oral statements about the product made by the seller, Decko Products, the representatives, or any other parties do not constitute warranties, shall not be relied upon by the user, and are not part of the contract for sale. Seller's and Decko Products only obligation, and buyer's only remedy, shall be the replacement and/or repair by Decko Products of the product as described above. NEITHER SELLER NOR DECKO PRODUCTS SHALL BE LIABLE FOR ANY INJURY, LOSS OR DAMAGE, DIRECT, INCIDENTAL OR CONSEQUENTIAL (INCLUDING, BUT NOT LIMITED TO, INCIDENTAL OR CONSEQUENTIAL DAMAGES FOR LOST PROFITS, LOST SALES, INJURY TO PERSON OR PROPERTY, OR ANY OTHER INCIDENTAL OR CONSEQUENTIAL LOSS), ARISING OUT OF THE USE OR THE INABILITY TO USE THE PRODUCT, AND THE USER AGREES THAT NO OTHER REMEDY SHALL BE AVAILABLE TO IT. Before using, the user shall determine the suitability of the product for his/her intended use, and user assumes all risk and liability whatsoever in connection therewith.

THE WARRANTY AND REMEDY DESCRIBED IN THIS LIMITED WARRANTY IS AN EXCLUSIVE WARRANTY AND REMEDY AND IS IN LIEU OF ANY OTHER WARRANTY OR REMEDY, EXPRESSED OR IMPLIED, WHICH OTHER WARRANTIES AND REMEDIES ARE HEREBY EXPRESSLY EXCLUDED, INCLUDING BUT NOT LIMITED TO ANY IMPLIED WARRANTY OF MERCHANTABILITY OR FITNESS FOR A PARTICULAR PURPOSE, TO THE EXTENT EITHER APPLIES TO A PRODUCT SHALL BE LIMITED IN DURATION TO THE PERIODS OF THE EXPRESSED WARRANTIES GIVEN ABOVE.

Some states and countries do not allow the exclusion or limitations on how long an implied warranty lasts or the exclusion or limitation of incidental or consequential damages, so the above exclusion or limitations may not apply to you. This warranty gives you specific legal rights, and you may also have other rights which vary from state to state.



OWNER'S MANUAL

INSTALLATION AND OPERATION INSTRUCTIONS FOR UTILITY TRANSFER PUMP

**Model:
90050**

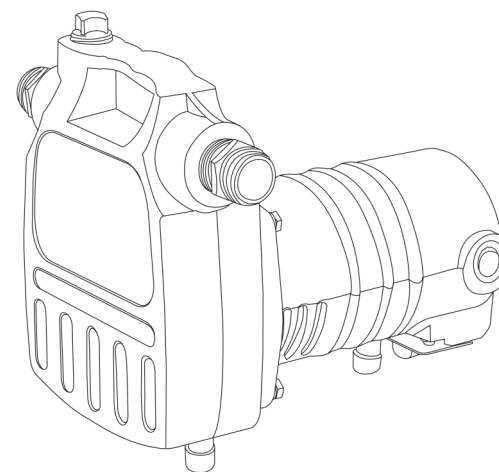

Safety Guidelines

Carefully read, understand and follow all safety instructions in this manual.

! This is the safety alert symbol. When you see this symbol, look for one of the following signal words.

⚠ DANGER Indicates a hazardous situation which, if not avoided, will result in death or serious injury.

⚠ CAUTION Indicates a hazardous situation which, if not avoided, could result in death or serious injury.

⚠ WARNING Indicates a hazardous situation which, if not avoided, could result in minor or moderate injury.

Safety Information

Read these warnings carefully. Know the application and limitations of this pump. Failure to follow these warnings could result in serious bodily injury and/or property damage.

⚠ DANGER *This pump is not submersible. Do not submerge the motor in water or expose to water. Personal injury and/or death could result from electric shock.*

⚠ DANGER *Do not use to pump flammable or explosive liquids such as gasoline, kerosene, fuel oil, etc. Personal injury and / or death could result. Do not use this pump in a flammable or explosive environment. This pump is intended to pump clear water only.*

⚠ DANGER *RISK OF ELECTRICAL SHOCK. This pump is supplied with a grounding conductor and grounding type attachment plug. To reduce the risk of electric shock, be certain that it is connected only to a properly grounded, grounding type receptacle. For added safety, it is highly recommended to connect this pump to a GFCI (Ground Fault Circuit Interrupter) outlet. Never remove the grounding blade from the plug.*

⚠ WARNING *RISK OF ELECTRICAL SHOCK. This pump has not been investigated for use in swimming pool or marine areas.*

⚠ DANGER *Do not touch this pump while standing in or walking on wet surfaces until all power is turned off. Failure to follow this warning could result in electric shock.*

⚠ WARNING *RISK OF ELECTRICAL SHOCK. Do not use the power cord to carry or lift the pump. Doing so may cause the wire insulation to be exposed. Protect the cord from sharp objects, hot surfaces, oil and chemicals.*

Specifications

*3/4" Garden Hose Adapters Included

HP	Volts	Amps	Hz	Suction/Discharge	Construction	Max. Liquid Temperature	Cord Length
1/2	120	8.4	60	3/4" NPT*	Cast Iron	120°F	10 Feet

Circuit Requirements.....15 Amp

Motor Bearings.....Permanently Lubricated Ball Bearings

Replacement Parts

To order replacement parts call
1-800-495-9278

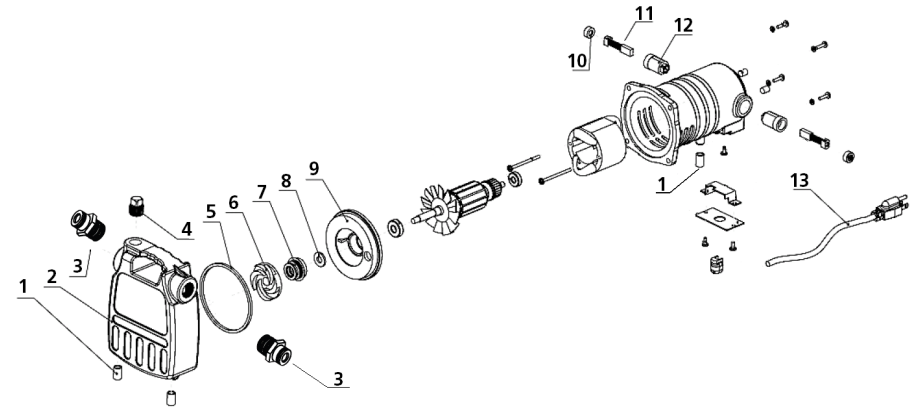

Ref#	Description	Part #
1	Rubber Bumper	99670
2	Volute	99671
3	3/4" NPT x 3/4" GHT Adapter	99672
4	Priming Plug	99673
5	Gasket	99674
6	Impeller	99675
7	Shaft Seal	99676
8	Washer	99677
9	Seal Plate	99678
10	Brush Cap	99679
11	Brush	99680
12	Brush Holder	99681
13	Power Cord	99682

Performances

NOTICE Height and/or piping restriction will reduce the pump output performance. It is recommended to use the same size or larger pipe as the pump discharge for optimum performance.

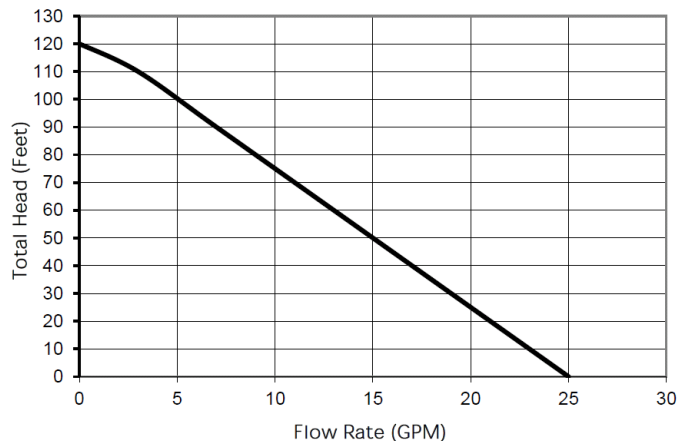

Discharge Height	0'	30'	60'	90'	110'
Gallons Per Minute	25	19	13	7	3
Gallons Per Hour	1500	1140	780	420	180

Troubleshooting

PROBLEM	POSSIBLE CAUSES	HOW TO CORRECT
If the pump does not start or run	Pump is not plugged in, switch or breaker is off	Plug pump in or turn on switch/breaker
	Check for blown fuses, tripped circuit breakers or tripped GFCI outlets.	Replace fuse, reset breaker, reset GFCI outlet
	Low line voltage	Check voltage & wire size and increase if necessary
	Obstructed impeller	Check and remove obstruction
	Worn brushes	Replace Brushes
Pump will not prime or retain prime	Air leak in suction line	Check for leaks. Use thread sealant if necessary
	Worn seal/gasket	Inspect and replace if necessary
	Suction lift too high	Lower pump closer to water source
If the pump runs but moves little or no water	Clogged intake screen	Clean or replace screen
	Clogged or kinked discharge hose/pipe	Remove kink or clog
	Frozen discharge hose/pipe	Allow hose/pipe to thaw
	Air leak in suction line	Check for leaks. Use thread sealant if necessary
	Low line voltage	Check wire size and increase if necessary
	Worn, damaged or clogged pump parts	Inspect for wear, damage or clog and clean or replace if necessary
	Discharge or suction lift exceeds pump capacity	Lower pump closer to water source and/or decrease discharge height
	Suction end of hose out of water	Submerge suction line in water.
Pump Leaks	Worn shaft seal	Inspect and replace if necessary
	Worn housing gasket	Inspect and replace if necessary

Installation

⚠ DANGER Always disconnect the power source before attempting to install, service or perform maintenance. If the power source is out of sight, lock and tag in the off position to prevent unintended power application. Failure to do so could result in fatal electric shock. All wiring should be performed by a qualified electrician.

PIPING

- The inlet and discharge ports are 3/4" Female NPT. Standard water pipe can be threaded into the pump housing. If garden hose is to be used, thread the adapters (included) into the housing. See Figure 1. It is recommended to use thread seal tape or pipe joint compound on the threads to ensure a tight seal. **NOTE:** Standard garden hose may collapse under suction pressure. To reduce the possibility of hose collapse, use a reinforced hose on the suction line such as PVC, plastic or galvanized pipe.
- The maximum suction lift of the pump is 15 feet. Install a foot valve (sold separately) when the suction lift is over 10 feet.
- Use the included strainer on the suction line when pumping from a pond or stream to prevent foreign objects from entering the pump housing.

PRIMING

⚠ CAUTION Do not run the pump dry. The pump housing must be filled with water before operating. Running the pump dry will cause damage to the shaft seal and result in premature failure of the pump. Running the pump dry will void the warranty.

- Remove the priming plug on top of the pump housing. See Figure 1.
- Fill the pump with clean water until it reaches the top of the housing.
- Replace and re-tighten the priming plug.

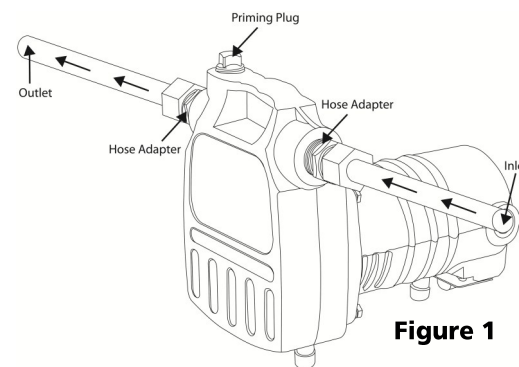

Figure 1

Operation

- Once the pump is filled with water, plug the power cord into a grounded outlet. The use of a GFCI outlet is highly recommended. It is recommended to plug the cord directly into the outlet. If the use of an extension cord is required, follow the extension cord chart on page 4 for proper gauge of cord to be used.
- The pump should prime within a minute of starting depending on the length of suction hose.
- When finished pumping unplug the cord to turn the unit off.

Operation (Continued)

⚠ CAUTION *The pump retains water in the housing after use. In areas that are prone to freezing, be sure to drain the pump before storage to prevent damage from freezing water.*

EXTENSION CORD LENGTH TABLE

Wire Gauge	18 AWG	16 AWG	14 AWG	12 AWG
Length	25 feet	50 feet	100 feet	150 feet

Maintenance

⚠ DANGER *Always disconnect the power source before attempting to install, service or perform maintenance. If the power source is out of sight, lock and tag in the off position to prevent unintended power application. Failure to do so could result in fatal electric shock.*

⚠ WARNING *Allow the pump to cool before servicing. The motor may be extremely hot and could result in personal injury.*

BRUSH INSPECTION AND REPLACEMENT

NOTICE Brushes should be inspected after each 100 hours of use. Pumps with 100 hours or more of operation may stop operating or fail to start. This could be due to worn brushes or carbon build up. The brushes should be removed and cleaned of carbon. **NOTE:** If brushes are to be reused, mark the location of each brush (left & right) and reinstall on the same side. Brushes are a normal wear item and not covered under warranty. An extra set of brushes are included with this pump. If additional replacement brushes are required, call 1-800-495-9278 to order. Brush replacement should be scheduled after approximately 300 hours of use.

1. Unplug power cord from outlet.
2. Remove brush caps with a screwdriver. See Figure 2.
3. Remove old brushes. Take note of brush orientation.
4. Insert new brush assembly into brush holder
5. Replace brush caps.

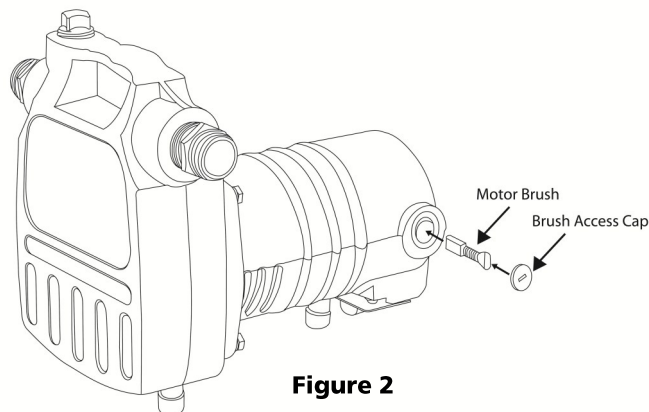

Figure 2

Maintenance (continued)

IMPELLER / SHAFT SEAL REPLACEMENT

1. Unplug the power cord from the outlet
2. Disconnect suction and discharge lines
3. Empty water from pump housing.
4. Remove the brushes per "BRUSH INSPECTION AND REPLACEMENT" instructions.
5. Remove the four bolts holding the motor to the pump housing. Remove pump housing from motor. Gently tap the housing with a rubber mallet if necessary.
6. The entire motor commutator (rotor) can now be removed. Using a screwdriver, gently pry the seal plate from the motor housing. The entire commutator should come out of the motor housing.
7. To remove the impeller, hold the commutator and turn the impeller counter clockwise (right hand thread).
8. To replace the shaft seal, gently pry the seal from the seal plate using a screwdriver. Avoid touching or scratching the polished surface of the seal. Dirt, grit or oil may cause premature failure of the seal.
9. Using a screwdriver, gently pry the ceramic half of the seal out of the impeller. Avoid touching or scratching the polished ceramic surface of the seal. Dirt, grit or oil may cause premature failure of the seal.
10. Installation is in reverse order starting with step 7.

Storage

1. Be certain to drain all water from pump housing before storage. If necessary, place a small amount of RTV antifreeze in the pump housing to protect from freezing and corrosion
2. Store indoors in a dry environment.