



**Models 1300/1400/1500/1537G**  
OWNER'S MANUAL

# **SOLID FUEL WARM AIR FURNACE**

- \* FOR PARALLEL INSTALLATION WITH EXISTING FORCED AIR-GAS OR OIL FIRED FURNACE (U.S. ONLY)
- \* FOR INSTALLATION AS A CENTRAL FURNACE
- \* THE 1500 & 1537G HOTBLAST FURNACES HAVE BEEN APPROVED FOR U.S. INSTALLATIONS ONLY.
- \* ALL MODELS CERTIFIED UNDER *UL 391*
- \* MODELS 1300/1400 ARE ALSO CERTIFIED UNDER *CAN/CSA-B366.1-M91*
- \* MODEL 1400 IS *WOOD ONLY*

**CAUTION:**  
READ ALL INSTRUCTIONS CAREFULLY BEFORE STARTING THE INSTALLATION OR OPERATING THE FURNACE

**IMPROPER INSTALLATION MAY VOID YOUR WARRANTY**

**DO NOT USE THIS FURNACE IN A MOBILE HOME OR TRAILER**



**UNITED STATES STOVE COMPANY**

227 Industrial Park Road  
P.O. Box 151  
South Pittsburg, TN 37380  
(423) 837-2100  
[www.USSTOVE.com](http://www.USSTOVE.com)



# CONGRATULATIONS!

You've purchased one of America's Finest Wood and Coal Burning Furnaces. By heating with wood and coal you're helping CONSERVE AMERICA'S ENERGY! Wood is our Renewable Energy Resource. Please do your part to preserve our wood supply. Plant at least one tree each year. Future generations will thank you.

**NOTE: YOUR UNIT MUST BE INSTALLED BY A QUALIFIED FURNACE INSTALLER.**

## TOOLS AND MATERIALS NEEDED

### TOOLS

Pencil  
6 Foot Folding Rule or Tape  
Tin Snips  
Drill, Hand or Electric  
Drill Bit- 1/8" Dia.  
(For Sheet Metal Screws)  
Screw Driver (Blade-Type)  
Gloves  
Sabre Saw  
5/16" Nut Driver or  
5/16" Socket w/Ratchet  
Safety Glasses

### MATERIAL

6" Pipe, 6" Elbow, Collar and Thimble;  
as required (24 gauge min.)  
1/2" Sheet Metal Screws  
6" Inside diameter Listed Residential  
Type or Building Heating Appliance  
Chimney or existing masonry chimney  
Electrical Wiring  
6" Draft Regulator  
1/2" Conduit (Conduit Connectors)  
Furnace Cement (Manufacturer  
Recommends: Rutland Black-Code 78  
or Equivalent)  
Plenum and Duct work as required.

# Caution Labels

Your Furnace has the following labels. Read and Obey all labels.

**DANGER: RISK OF FIRE OR EXPLOSION.**

**DO NOT** burn garbage, gasoline, drain oil, or other flammable liquids.

**WARNING: FIRE HAZARD.**

**DO NOT** operate with fire draft exceeding .06 inches w.c.

**DO NOT** operate with fuel loading or ash removal doors open.

**DO NOT** store fuels, paints, thinners, flammable liquids, or other highly volatile substances in the furnace room.

**CAUTION:**

**HOT SURFACES! Keep children away. Do not touch during operation.**

**CAUTION!**

INSPECT FLUE PIPES, FLUE PIPE JOINTS AND FLUE PIPE SEALS REGULARLY TO ENSURE THAT SMOKE AND FLUE GASES ARE NOT DRAWN INTO, AND CIRCULATED BY, THE AIR CIRCULATION SYSTEM.

**CAUTION!**

CLEANOUT OF THE HEAT EXCHANGER, FLUE PIPE, CHIMNEY, AND DRAFT INDUCER (IF USED), IS ESPECIALLY IMPORTANT AT THE END OF THE HEATING SEASON TO MINIMIZE CORROSION DURING THE SUMMER MONTHS, CAUSED BY ACCUMULATED ASH.

**SAFETY NOTICE:**

If this heater is not properly installed, a house fire may result. For your safety, follow the installation directions. Contact local building or fire officials about restrictions and installation inspection requirements in your area. If not already installed, we recommend that smoke detectors be installed.

## Rules for safe installation and operation

Read these rules and the instructions carefully. Failure to follow them will cause a hazard that could result in death, serious bodily injury, and/or property damage.

1. Check your local codes. The installation must comply with their rulings.
2. Do not install this furnace in a mobile home or trailer.
3. Always connect this furnace to a chimney and vent to the outside. Never vent to another room or inside a building.
4. Do not connect this furnace to an aluminum Type B gas vent. This is not safe and is prohibited by the National Fire Protection Association Code. This furnace requires a masonry or Listed Factory Built Chimney for residential type or Building Heating Appliance Chimney. Use a 6" diameter chimney or larger, that is high enough to give a good draft.
5. Be sure that if a masonry chimney is used, it is safely constructed and in good repair. Have the chimney inspected by the Fire Department or an inspector.
6. Inspect chimney connector and chimney before and frequently during the heating season for any deposit of creosote or soot which must be removed.
7. Provide air for combustion into the room where the furnace is located. If the intake is not in the same room, air must have free access to the room.
8. CAST IRON PARTS MUST BE "SEASONED" TO AVOID CRACKING, BUILD ONLY SMALL FIRES ON FIRST USE.
9. To prevent injury, do not allow anyone to use this furnace who is unfamiliar with the correct operation of the furnace.
10. For further information on using your furnace safely, obtain a copy of the National Fire Protection Association (NFPA) publication "Chimney's, Fireplaces and Solid Fuel Burning Appliances" NFPA 211. The address of the NFPA is Batterymarch Park, Quincy, MA 02269.
11. Keep the ashpit section free of excess ashes. Do not allow ashes to stack higher than the sides of the ash pan.
12. DISPOSAL OF ASHES- Place ashes in a metal container with a tight fitting lid. Keep the closed container on a noncombustible floor or on the ground, well away from all combustible materials. Keep the ashes in the closed container until all cinders have thoroughly cooled. The ashes may be buried in the ground or picked up by a refuse collector.
13. CAUTION- The special paints used on your furnace may give off some smoke while they are curing during first few fires., Build small fires at first. The metal used in construction of the furnace and duct work has a light coating of oil. This could give off smoke and/or odor from registers when furnace is used for the first time. This should disappear after a short period of time. Once this burn-off has occurred, it should not reoccur.
14. CARING FOR PAINTED PARTS- This furnace has a painted outside jacket, which is durable, but it will not stand rough handling or abuse. When installing your furnace, use care in handling. Clean with soap and warm water when furnace is not hot. DO NOT use any acids or scouring soap, as these wear and dull the finish. DISCOLORATION WILL OCCUR IF THE FURNACE IS OVERHEATED. FOLLOW OPERATING INSTRUCTIONS CAREFULLY.
15. Keep the feed and ash doors closed at all times except while tending the furnace.

---

### CAUTION

---

**GASES THAT ARE DRIVEN FROM FRESH COAL MUST BE BURNED OR THEY WILL ACCUMULATE AND EXPLODE. NEVER SMOTHER A FIRE WHEN ADDING FRESH COAL.**

---

### CAUTION

---

**DO NOT OPERATE WITH THE FEED AND/OR ASH DOOR OPEN. THIS FURNACE IS DESIGNED FOR THERMOSTATIC OPERATION. OPERATION WITH ANY OF THESE DOORS OPEN WILL OVERHEAT AND DAMAGE THE FURNACE.**

---

### CAUTION

---

**NEVER USE GASOLINE, GASOLINE-TYPE LANTERN FUEL, KEROSENE, CHARCOAL LIGHTER FLUID, OR FLAMMABLE LIQUIDS TO START OR "FRESHEN UP" A FIRE IN THE FURNACE.**

---

### WARNING

---

**NEVER STORE FLAMMABLE LIQUIDS, ESPECIALLY GASOLINE, IN THE VICINITY OF THE FURNACE.**

***Your Furnace is designed to be installed in a parallel air flow arrangement with a gas or oil-fired forced air upflow-type central furnace, or it may be installed as a central furnace.***

# HOW THE FURNACE FUNCTIONS

Your HOTBLAST Furnace is designed to be a supplemental or central heating source for your home. This Solid Fuel Furnace may be installed in conjunction with a properly operating central furnace that is listed or certified in accordance with nationally recognized safety standards and equipped with the required controls and other safety features and which has been installed in accordance with appropriate standards of the National Fire Protection Association with installation clearances specified in the furnace nameplate marking. The installation must be accomplished by a qualified agency (one who is engaged in, and is responsible for, or is thoroughly familiar with the installation and operation of the gas, oil, and solid fuel burning heating appliances, who is experienced in such work, familiar with all the requirements of the authority having jurisdiction.) The installation shall be in strict accordance with the manufacturer's installation instructions furnished with the solid fuel furnace.

The chimney connector of the furnace is to be installed to provide clearances to combustible material not less than specified in the individual classifications and marked on the furnace. The chimney connector must be connected to a chimney suitable for use with residential type or building heating appliances which burn solid fuel.

The Furnace is designed to operate in either parallel or series air flow arrangement with the central furnace or as a central furnace.

## **CENTRAL FURNACE INSTALLATION:**

As a central furnace, the unit functions independently of any other system. The blower will come on when the plenum temperature reaches the setting on the blower control.

## **PARALLEL INSTALLATION: (U.S. ONLY)**

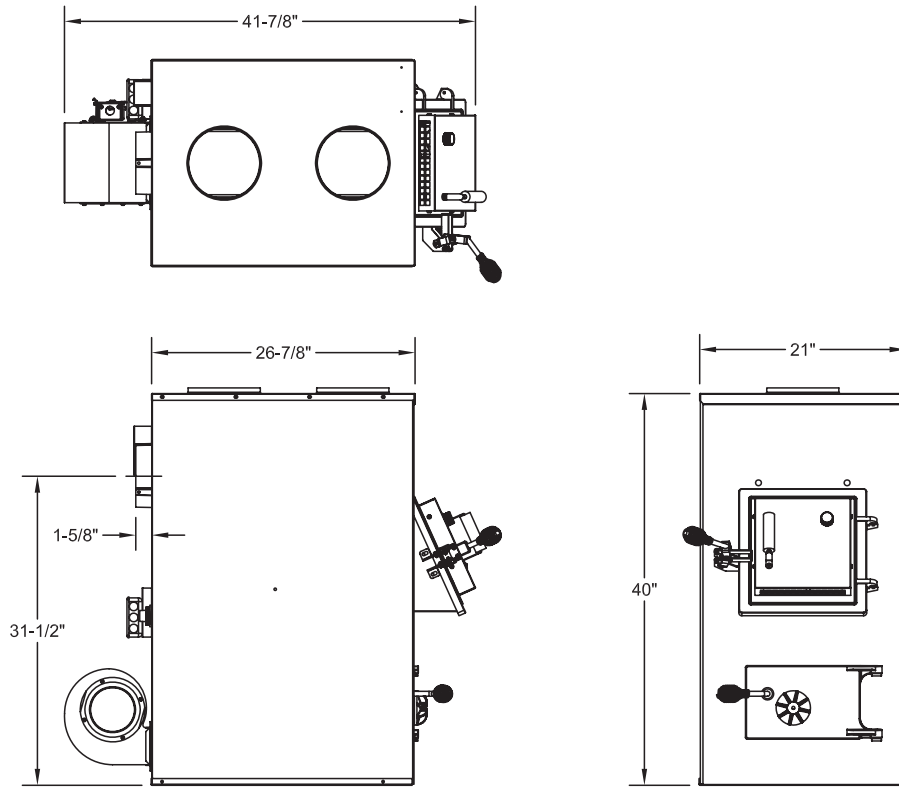
The design is such that when the blower comes on, the blower on the central system also comes on. The blower will only come on when the temperature in the plenum has reached the setting on the blower control. This is to insure that there is sufficient warm air in the system to make it efficient for the unit to operate. When the central system thermostat calls for heat, the central system will operate by the burner igniting and the blower coming on. It is possible that both systems will operate simultaneously. It is recommended that for the most efficient use of your HOTBLAST Furnace, that it be fired as much as possible in order to reduce the demand on your existing central heating system. This unit has an optional forced draft kit that operates from a wall thermostat. When the temperature falls below the setting on the wall thermostat, the forced draft will come on (U.S. Stove Option 11/DIKL)

The warm air supply outlet of the HOTBLAST Furnace shall not be connected to the cold air return of the central furnace, because the possibility exists of components of the central furnace overheating and causing the central furnace to operate other than is intended.

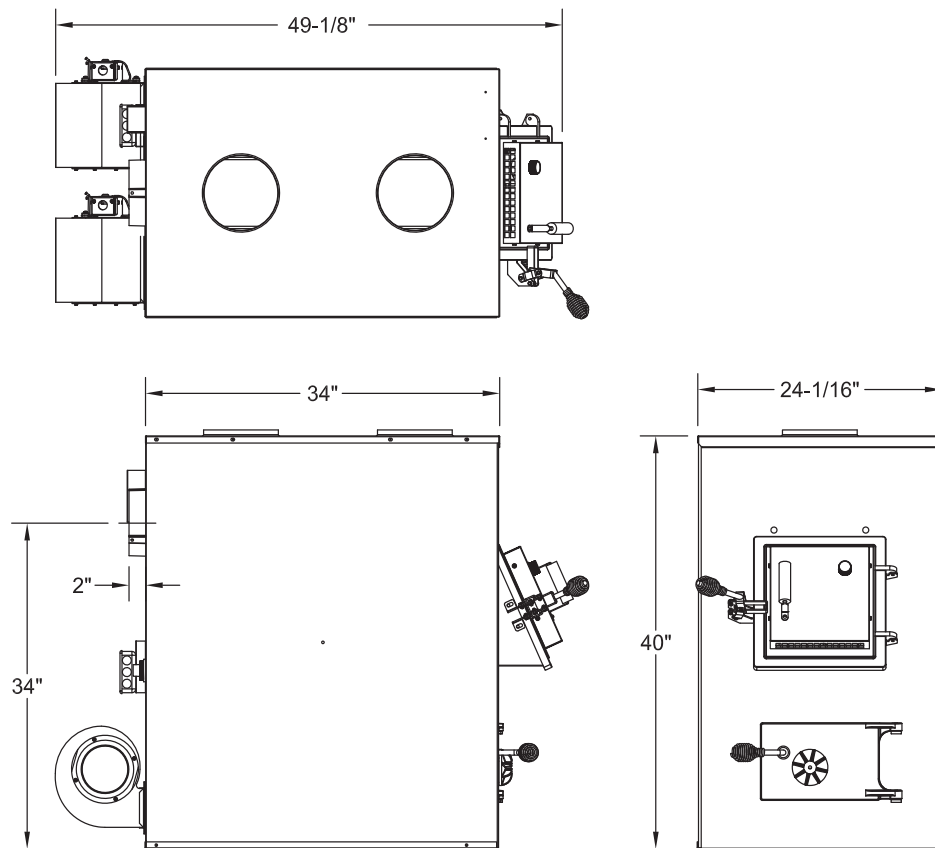
## **SERIES INSTALLATION:**

This type of installation uses only the blowers of the existing central furnace. The solid fuel fan/limit control must also control the functions of the existing furnace. All electrical power must come from a single branch circuit.

# DIMENSIONS OF FURNACE



**Figure 1**  
**Model 1300**



**Figure 2**  
**Models**  
**1400/1500/1537G**

# Locating the Furnace

1. The furnace should be located in the same room as the central system and as close as possible, but not closer than 9". There should be no wall between the furnace and the warm air outlet duct that is connected directly to the warm air outlet plenum of the central furnace. (See Fig. 4)
2. Place the furnace on a noncombustible floor.
3. Check figures 3 through 5. Be sure you have the clearances shown below from the furnace and the connector pipe to combustible surfaces. If you have a solid brick or stone wall behind your furnace, you can place the furnace as close as you wish to the wall. If the wall is only faced with brick or stone, treat it as a combustible wall.

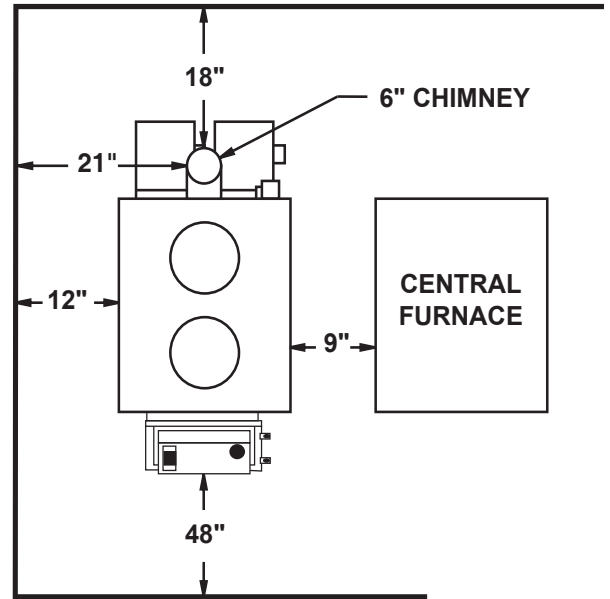


Figure 4

	1300	1400	1500	1537G
Unit to Sidewall	12" (305mm)	12" (305mm)	12" (305mm)	12" (305mm)
Unit to Backwall	30" (760mm)	30" (760mm)	30" (760mm)	30" (760mm)
Front of Unit to Combustible	48" (1.22m)	48" (1.22m)	48" (1.22m)	48" (1.22m)
Chimney Pipe to Sidewall	18" (460mm)	18" (460mm)	21" (530mm)	21" (530mm)
Chimney Pipe to Backwall	18" (460mm)	18" (460mm)	18" (460mm)	18" (460mm)
Plenum to Combustibles	6" (150mm)	6" (150mm)	6" (150mm)	6" (150mm)

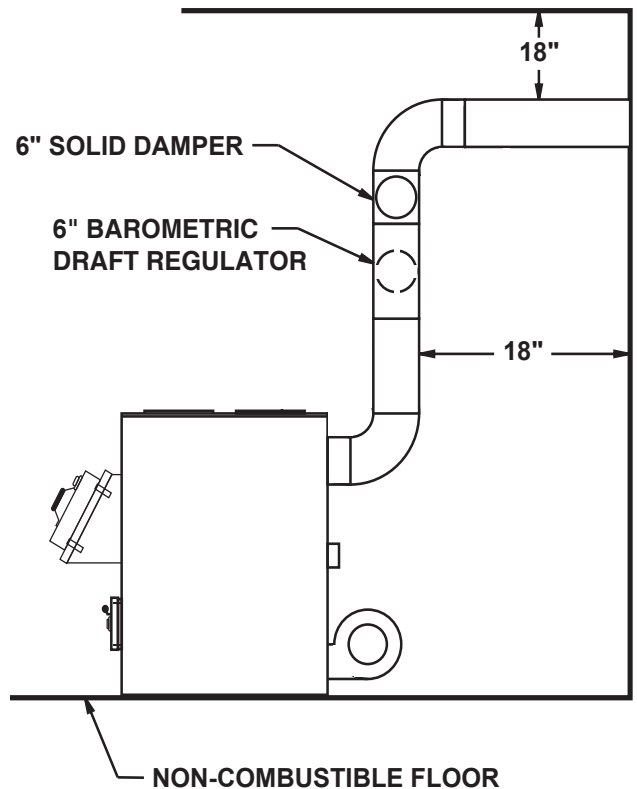


Figure 5

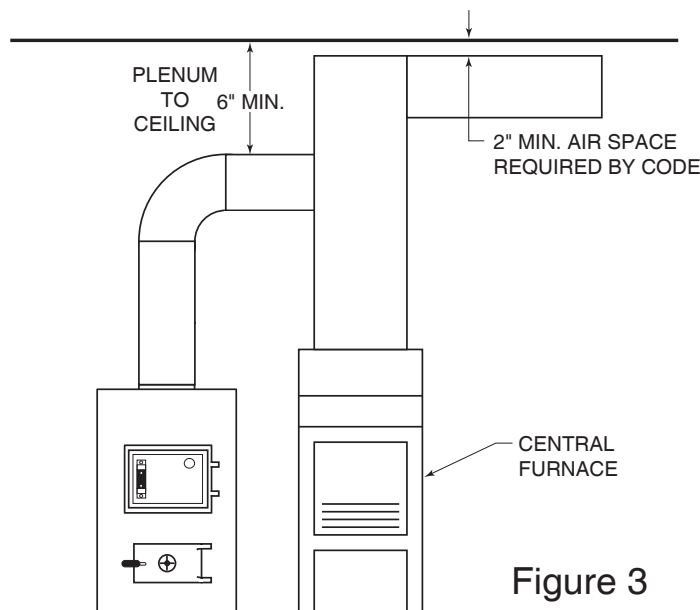


Figure 3



# Chimney Connection

## MASONRY CHIMNEY

Before using an existing masonry chimney, clean the chimney and inspect the flue liner to be sure it is safe to use. Make repairs before attaching the furnace. The connector pipe and fittings you will need to connect directly to a masonry chimney are shown.

The chimney connection should be as short as possible.

If the connector pipe must go through a combustible wall before entering the masonry chimney, consult a qualified mason or chimney dealer. The installation must conform to local fire codes, and N.F.P.A. 211.

**DO NOT CONNECT THIS FURNACE TO A CHIMNEY FLUE SERVING ANOTHER APPLIANCE.**

The chimney used for a furnace must not be used to ventilate the cellar or basement. If there is a cleanout opening at the base of the chimney, close it tightly.

## LISTED FACTORY BUILT CHIMNEY

Carefully follow chimney manufacturer's instructions. Use only a Listed Residential Type or Building Heating Appliance Chimney. If your chimney starts at the ceiling (Fig. 7), you will need enough 6" pipe to reach the ceiling.

The top of the chimney must be at least 3 feet above the roof and be at least 2 feet higher than any point of the roof within 10 feet (Fig. 7).

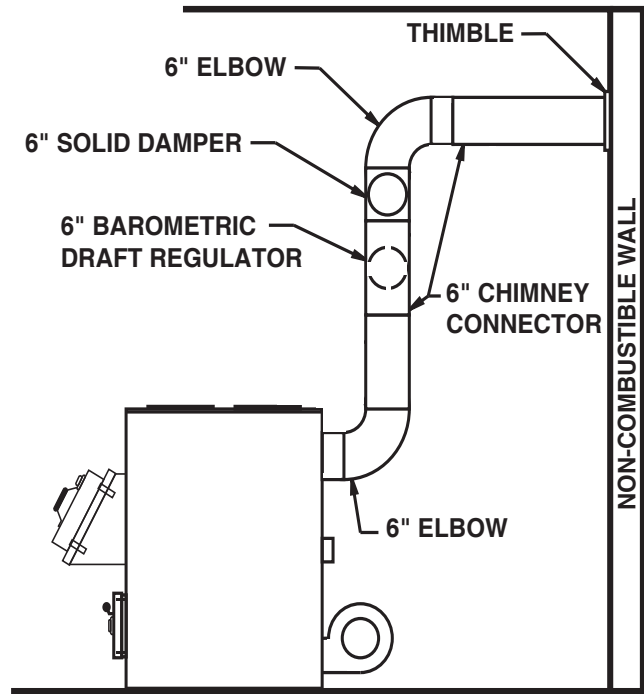


Figure 6

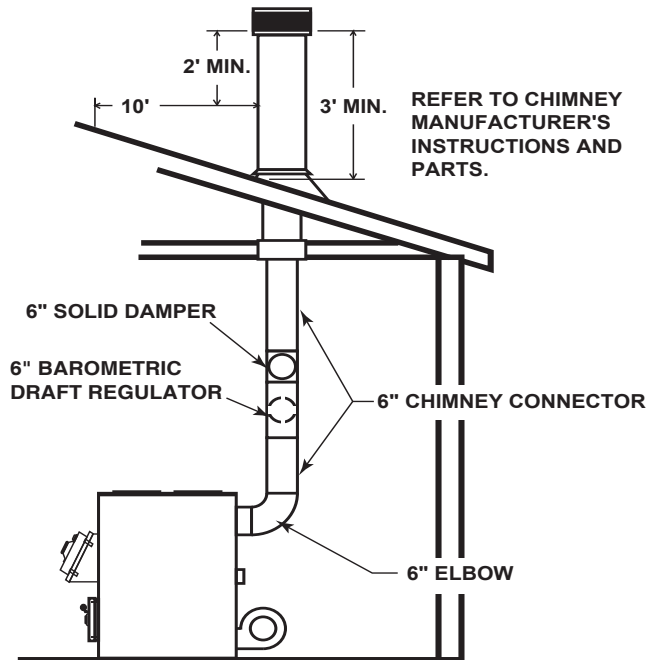


Figure 7



## Rules for Connector Pipe Installation

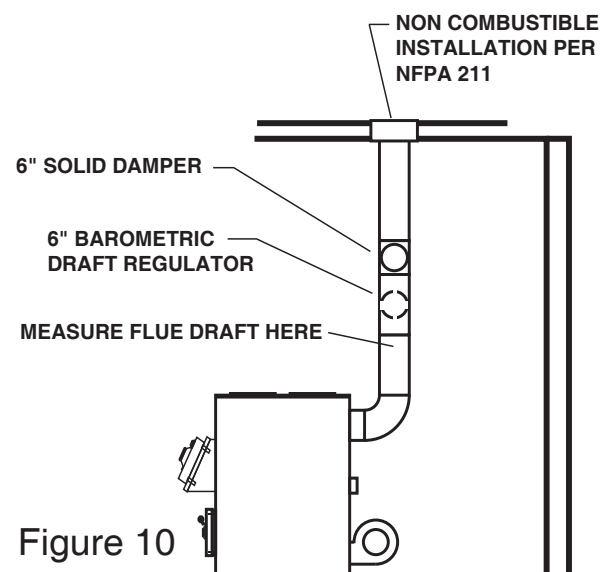
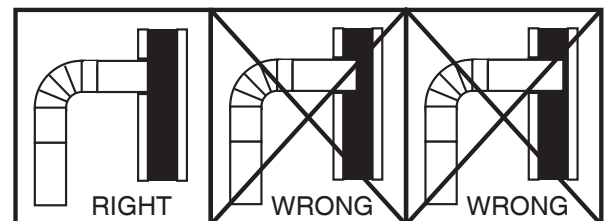
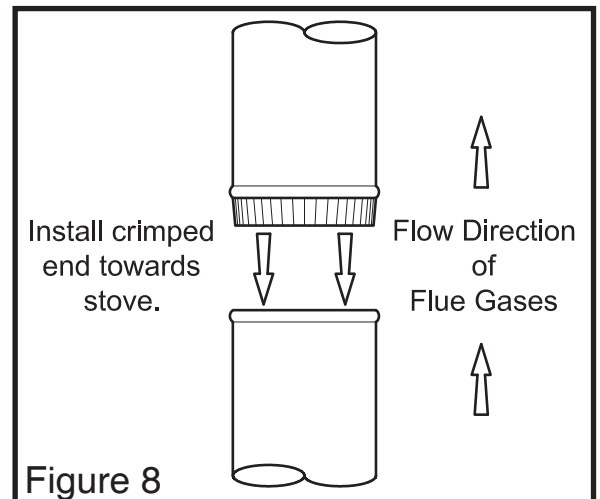
1. The crimped end of the chimney connector fits inside the furnace flue collar. Install additional chimney connectors and elbow with the **CRIMPED END TOWARD THE FURNACE**. This will allow any condensation in the flue to run back into the furnace. Use 6" dia. steel pipe and elbows for connection to chimney. Never use less than 24 gauge and although blued steel is satisfactory, high temp painted black is much more desirable. (See Figure 8)
2. Slope any horizontal pipe upward toward the chimney at least 1/4 inch for each foot of horizontal run.
3. You must have at least 18 inches of clearance between any horizontal piping and the ceiling. (See Fig. 5)
4. The chimney connector must not extend into the chimney flue. (See Fig. 9)
5. Seal each chimney connector pipe joint with furnace cement. Also seal the pipe at the chimney.
6. Use 3 sheet metal screws at each chimney pipe joint to make the piping rigid.
7. The chimney connector may include a section for a barometric draft regulator between the furnace and the chimney (Fig. 6, 7, & 10). The barometric draft regulator must be installed in the same room (same pressure zone) as the furnace.
8. Install the barometric draft regulator strictly in accordance with the instructions that are provided with the barometric draft regulator.
9. A solid damper must be used in the chimney connecting pipes between the flue collar and the chimney. When used in conjunction with a barometric draft regulator, the solid damper must be placed between the barometric and the chimney. (See Fig. 6, 7, & 10)

### Adjusting the Barometric Draft Regulator

1. Drill a hole in the chimney connector within 18" of the flue collar below the barometric draft regulator just large enough for the tube of the manometer.
2. Build a fire after all chimney connections have been made.
3. Use a manometer to measure the draft in the flue.
4. Adjust the Barometric Draft Regulator to obtain a draft of 0.05 - 0.06" W.C. under stable fire conditions.

#### NOTE:

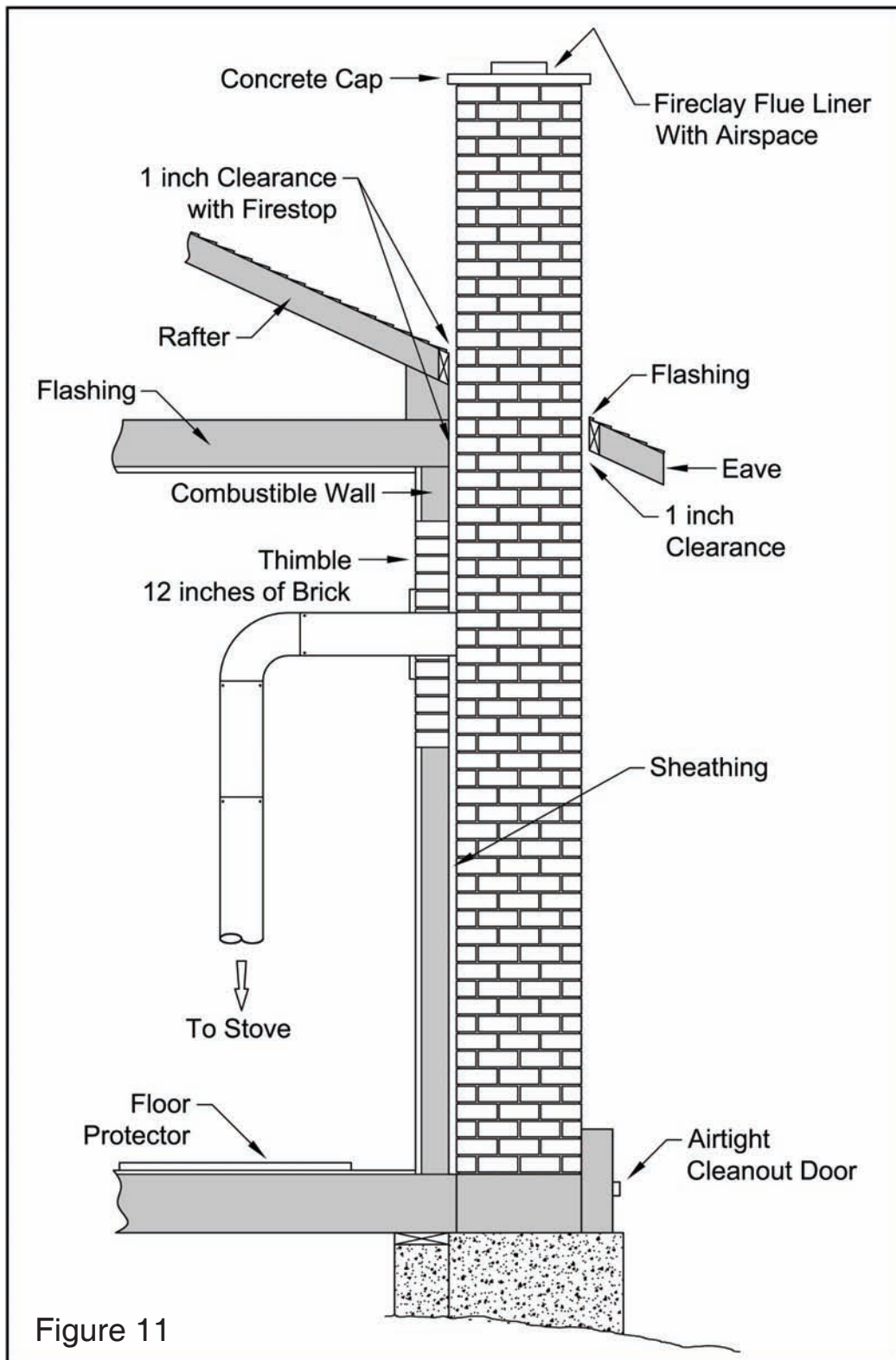
A flue pipe shall not pass through an attic, roof space, closet or similar concealed space, a floor or ceiling of combustible construction. Where passage through a wall or partition is desired, installation must conform with UL standards.



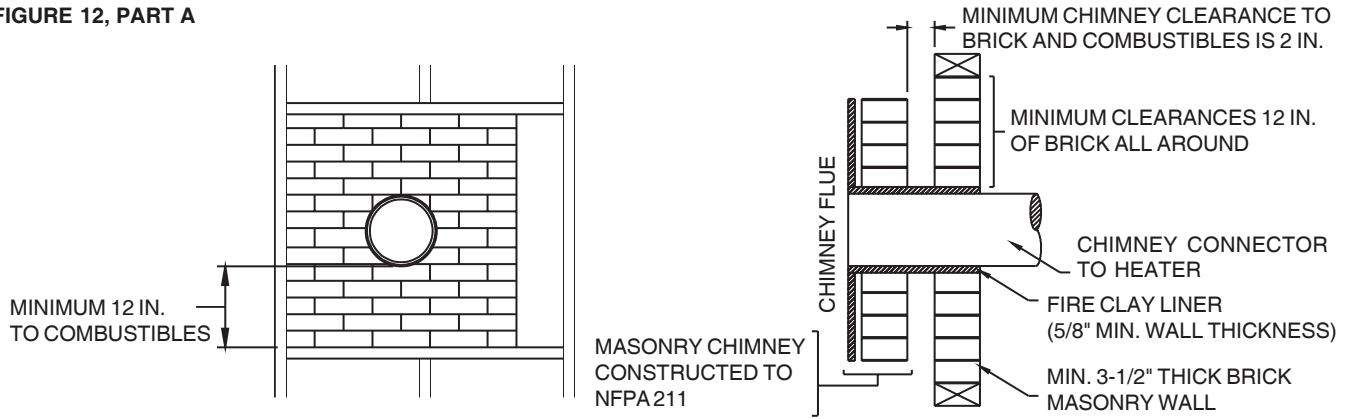
## CONNECTION OF CHIMNEY CONNECTOR TO A MASONRY CHIMNEY THROUGH A COMBUSTIBLE WALL

Figure 8 shows how to connect the chimney connector of a heater to a masonry chimney through a combustable wall.

There are five allowable ways that a chimney connector can be connected to a masonry chimney by passing through a combustable wall. NFPA Standard 211 allows the following wall pass-through systems.

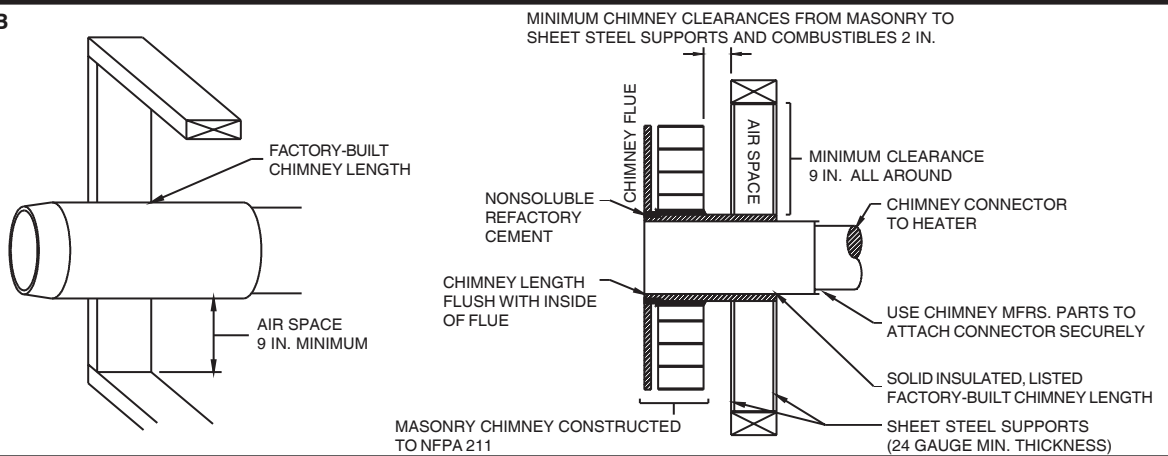


**FIGURE 12, PART A**



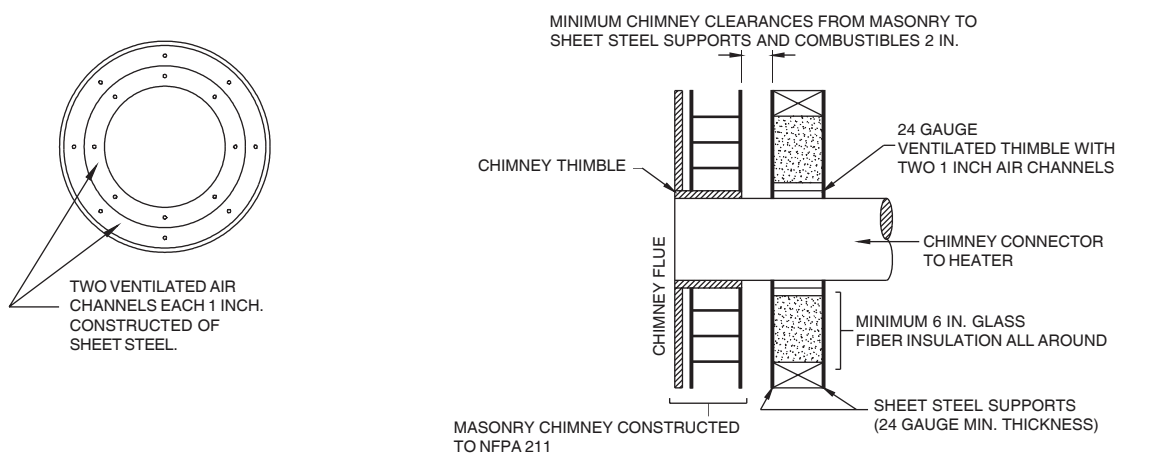
1. Use a minimum 3-1/2" thick brick masonry wall framed into the combustible wall. A fireclay liner (ASTM C315 or equivalent) having a 5/8" minimum wall thickness must be used and it must be at least 12" away from any material that could catch fire. The inside diameter of the fireclay liner shall be sized for the proper snug fit of a 6" diameter chimney connector pipe. The fireclay liner shall run from the outer surface of the brick wall to, but not beyond, the inner surface of the chimney flue and shall be firmly cemented in place. See Part A.

**FIGURE 12, PART B**



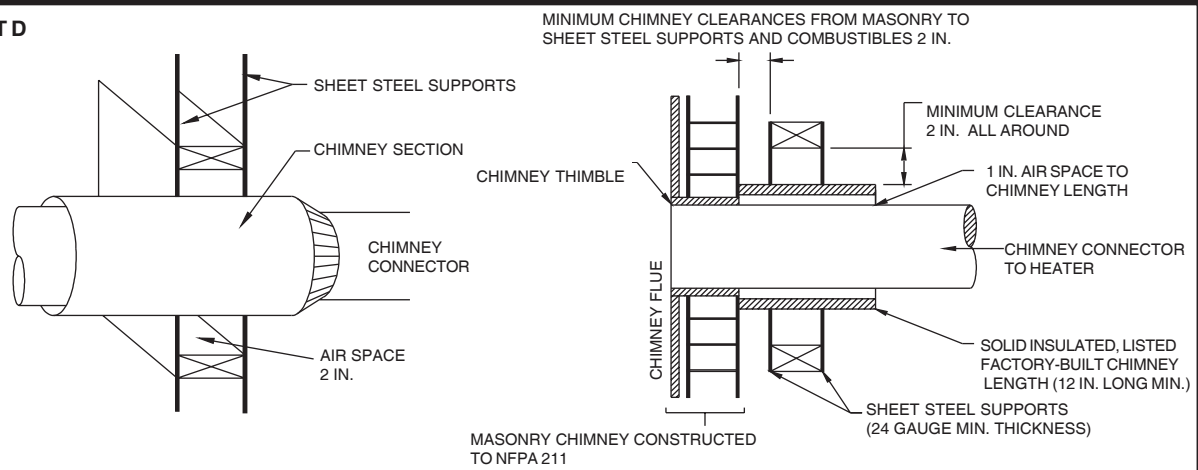
2. Use a solid insulated listed factory-built chimney length having an inside diameter of 6" and having 1" or more of solid insulation. There must be at least a 9" air space between the outer wall of the chimney length and any combustible materials. The inner end of the chimney length shall be flush with the inside of the masonry chimney flue and shall be sealed to the flue and to the brick masonry penetration with nonwater-soluble refractory cement. Sheet steel supports which are at least 24 gauge (0.024") in thickness shall be securely fastened to wall surfaces on all sides. Fasteners between supports and the chimney length shall not penetrate the chimney liner. See Part B.

**FIGURE 12, PART C**



3. Use a 10" diameter ventilated thimble made of at least 24 gauge (0.024") steel having two 1" air channels. The ventilated thimble must be separated from combustible materials by a minimum of 6" glass fiber insulation. The opening in the combustible wall shall be covered and the thimble supported with sheet steel supports which are at least 24 gauge (0.024") in thickness. The sheet steel supports shall be securely fastened to wall surfaces on all sides and shall be sized to fit and hold the chimney section. Fasteners used to secure chimney sections shall not penetrate chimney flue liner. See Part C.

**FIGURE 12, PART D**



4. Use an 8" inside diameter solid insulated listed factory-built chimney length which has 1" or more of solid insulation. The minimum length of this chimney section shall be 12" and will serve as a pass-through for the 6" diameter chimney connector. There must be at least a 12" air space between the outer wall of the chimney section and any combustible materials. The chimney section shall be concentric with and spaced 1" away from the chimney connector by means of sheet steel support plates on both ends of the chimney section. The opening in the combustible wall shall be covered and the chimney section supported on both sides with sheet steel supports which are at least 24 gauge (0.024") in thickness. The sheet steel supports shall be securely fastened to wall surfaces on all sides and shall be sized to fit and hold the chimney section. Fasteners used to secure chimney sections shall not penetrate chimney flue liner. See Part D.
5. A listed factory-built wall pass-through system may be purchased and installed according to the instructions packaged with it to provide a safe method of passing the chimney connector through a combustible wall for connection to a masonry chimney.

**Additional requirements pertaining to Figure 8 and the above wall pass-through systems:**

1. Insulation material used as part of wall pass-through system shall be of noncombustible material and shall have a thermal conductivity of 1.0 Btu • in./ft.<sup>2</sup> • °F (4.88 kg • cal/hr • m<sup>2</sup> • °C) or less.
2. All clearances and thicknesses are minimums: larger clearances and thickness are acceptable.
3. A chimney thimble, as shown for 3" and 4" above (Parts C and D) shall be for types "3" and 4" connections to facilitate removal of the chimney connector for cleaning. The chimney thimble shall be of ASTM C315 fireclay with 5/8" minimum wall thickness, or material or equivalent durability. The inside diameter of the thimble shall be sized for the proper snug fit of a 6" diameter chimney connector pipe. The thimble shall be installed without damage to the chimney flue. The thimble shall extend through the chimney wall to, but not beyond, the inner surface of the chimney flue and shall be permanently cemented in place with high temperature cement.
4. A chimney connector to a masonry chimney, except for 2" above (Part B), shall extend through the wall pass-through system to the inner face of the chimney flue, but not beyond. It does not have to be fastened in place so long as it cannot accidentally be pulled out of the chimney or shoved into the chimney flue. If fasteners are used to secure the chimney connector to a masonry chimney, the fasteners shall not penetrate the chimney flue liner.
5. Any material used to close up any opening for the connector shall be noncombustible.

**PART E - (Figure 12)**

In addition to the methods shown by A, B, C, and D of Figure 12, a listed factory-built wall pass-through system may be purchased and installed according to the instructions packaged with it to provide a safe method of passing chimney connector through a combustible wall for a connection to a masonry chimney.

**CONNECTION OF CHIMNEY CONNECTOR TO A MASONRY CHIMNEY WHEN CHIMNEY CONNECTOR DOES NOT PASS THROUGH A COMBUSTIBLE WALL**

If the chimney connector does not have to pass through a combustible wall to get to a masonry chimney, simply connect the chimney connector directly to the masonry chimney's chimney thimble as described and shown by parts C and D of Figure 12. Remember, the chimney connector should extend into the chimney thimble to the innerface of the chimney flue but not beyond; if the chimney connector is extended through the chimney thimble into the chimney flue, resistance to the flow of smoke and gases up the chimney will occur; that flow resistance will have an adverse affect on the operation and performance of the heater and venting system.

## Assembly of Furnace

Your furnace requires the following items to be assembled or installed by the service person:

Feed Door Pull Handle  
 Feed Door Locking Handle  
 Blowers and Blower Controls  
 Electrical Connections

1. Remove all parts from inside the furnace and inspect for damage, including the firebrick as some breakage could occur during shipment.
2. Assemble the feed door pull handle as shown in Figure 13. Install thermostat assembly and cover (complete with handle) as illustrated in Figure 13b.
3. Align thermostat control knob with flat on thermostat control shaft and press onto shaft. (See Fig. 13a)
4. Attach feed door locking handle as in Figure 14 with screws and nuts provided. Note: Slotted holes are for adjustment of handle. Adjust handle until some pressure is required to lock feed door during firing sequence.
5. Install the thermodisc on rear of furnace cabinet with the two screws provided. Mount the conduit assembly from the junction box to the thermostat bracket. Crimp the two female terminals to each of the wire leads. Plug the wires to the thermodisc. *NOTE: It does not matter which of the two wires plugs to which terminal on the thermodisc.*
6. Remove blowers from cartons. Remove junction box cover. Attach clip nuts as in Figure 15. Install blower(s) and gasket(s) with 1/4"-20 x 3/4" bolts as shown.
7. Wire right side blower first (See wiring diagram) and replace cover on junction box on blower.
8. Wire left blower same as above and replace cover.
9. Check operation of shaker grates with grate handle before operating furnace.

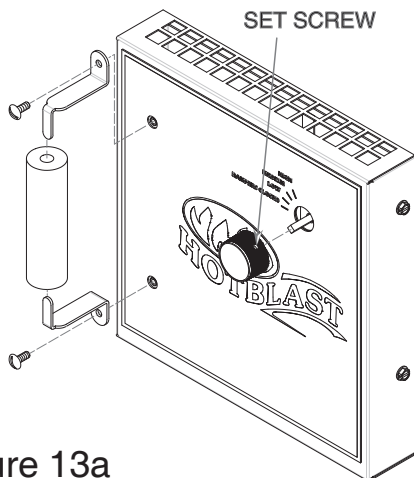


Figure 13a

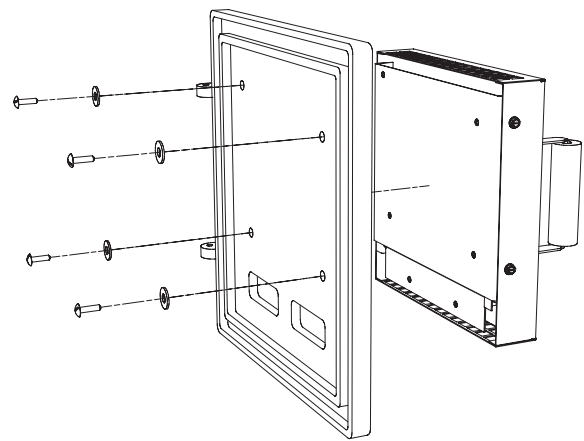


Figure 13b

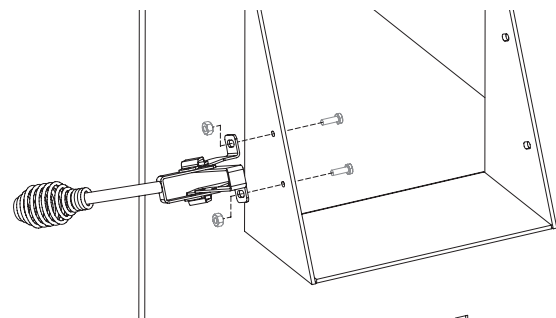


Figure 14

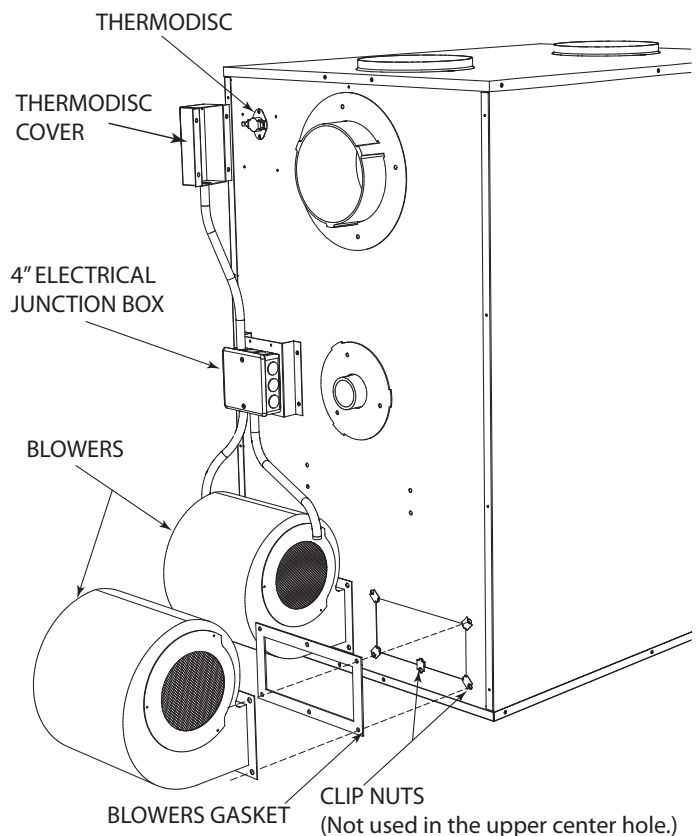


Figure 15  
 (Model 1300 has only one blower)

# WIRING DIAGRAM

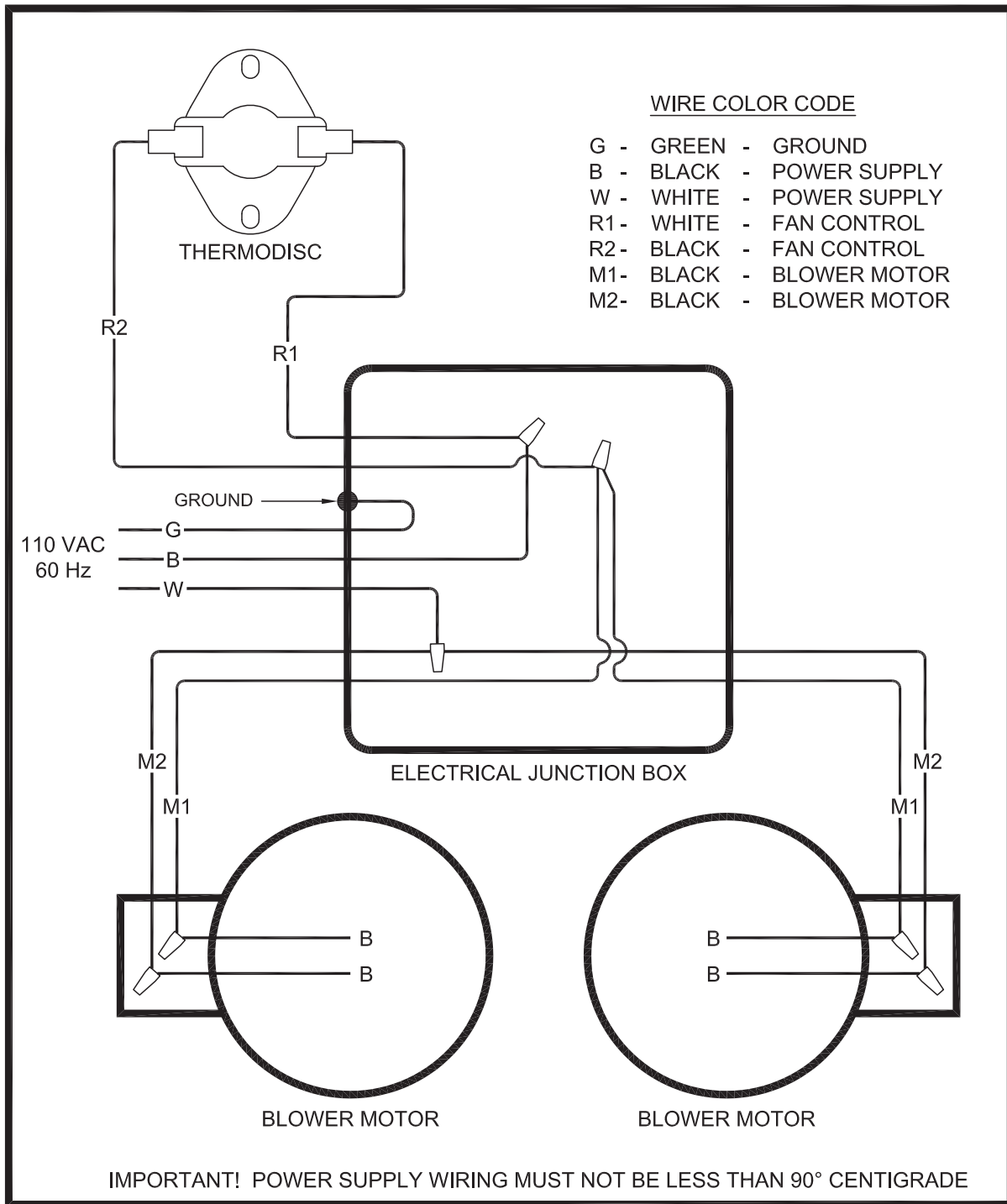


Figure 16

**NOTE:**  
***For model 1300, disregard the wiring (wires M1 & M2) of one blower motor.***  
 Wire leads from the distribution blower are usually BOTH BLACK.  
 Makes no difference which leads from the motor(s) connects to the corresponding leads coming out of the conduit.



# Installation

**Please see all methods of Installation at the rear of this booklet.**

This is a furnace, not a free standing stove. You must direct heated air from 8" outlets away from the furnace, or it will not function properly.

1. This installation must be done by a qualified heating equipment installer.
2. The installation is to be done in compliance with National Fire Protection Association installation standards: No. 89M, 90B, 211, 70 (National Electrical Code) and Uniform Mechanical Code 913, 6-4, in the states where applicable. (Their code offers connecting smoke pipe connectors into chimney with other fuel burning appliances.)
3. Rooms large in comparison with size of the appliance:
  - a) Wood or Coal Burning Furnace needs air for combustion and circulation to house.
  - b) Provision must be made to make up this air and not starve gas or oil furnace of combustion air.
  - c) Have the "Authority Having Jurisdiction" determine that air is of adequate makeup. (Reference N.F.P.A. Nos. 30&54, Code for Installation of Gas & Oil Equipment).
4. Have the "Authority Having Jurisdiction" to inspect all chimneys and installations for adequate venting and for compliance with standard and local codes and regulations regarding installation of wood burning appliances.
5. Installation for Supplemental Heat Application to Existing Central System.
  - a) Place Wood or Coal Burning Furnace so that the chimney connector will be as short as practical and avoiding unnecessary sharp turns in the smoke pipe connector and the installation of devices that would create excessive resistance to the flow of flue gases.
  - b) Locate the Wood or Coal Burning Furnace as close as practical to the existing central hot air heating system, maintaining clearances as stated on the label on the fuel door.
  - c) Clearance from combustible materials must comply with those stated on the label on the side of the unit. Refer to the clearance table in the front of this manual.

The installation must be made only on a noncombustible floor.

- d) Install the smoke pipe connector to the chimney with 26-gauge pipe and elbows (to be purchased separately), maintaining the proper clearances for the specific model. Seal the smoke pipe in the chimney with furnace cement. (The chimney connector shall be securely supported, and joints fastened with sheet metal screws or rivets.)
- e) Install 8" diameter heat pipe to plenum of the central hot air furnace. Use 26-gauge pipe and connectors (to be purchased separately). If central air conditioning is installed in the plenum, install heat pipe above the air conditioning unit. Secure heat pipe connection with supports and sheet metal screws.
- f) Connect electrical supply in the electrical junction box that is mounted on the back of the Furnace. See Wiring Diagram (Fig. 16). Remove the cover from electrical junction box and connect power supply wires to wires designated, using wire nuts. The power cord supplied may be used for installation, if permitted by local codes and regulations. If the power cord supplied cannot be used, the power supply wiring must be 90 degrees centigrade in a metal cable and should be completed by a qualified installer complying with NFPA Standard No. 70 and local codes.

## Power Failure Instructions

**Operation after loss of power:**

1. **Remove filter if provided**
2. **Do not expect to keep home at normal temperatures.**
3. **Do not load fuel above bottom of feed door.**



# Operating Instructions

## FUEL

Models 1300, 1500, 1537G (1400 is **WOOD ONLY**)

Egg size (1-3/16" or larger) bituminous coal for residential furnaces, or any of the specially packed fireplace coals can be used. Coal with a low ash content (2% to 6%) is recommended.

Hardwood, 18" to 26" should be split and air dried (seasoned) for 6 months.

## LIGHTING

1. Set the thermostat on "HIGH" for maximum draft.
2. Open the feed door and place paper and kindling on the grate for starting the fire.
3. Light the fire and close the feed door.
4. Add wood or about 15 lbs. of coal (depending on which model) after fire is burning briskly.
5. "MEDIUM" setting is normally satisfactory. Set higher or lower for your comfort.

## ADDING FUEL

When starting a fire, add small amounts of fuel instead of adding large quantities of fuel. This will give more complete combustion and less build-up of tars or soot in the chimney.

1. Set thermostat to HIGH before opening feed door.
2. Wood fire: Add wood to a convenient level.
3. Coal Fire:
  - a.) Never smother the fire when adding coal. Gases from the accumulation smoke will explode under certain conditions. Add fresh kindling if the bed of coals has cooled.
  - b.) Add up to 20 lbs. of coal per loading. Never add coal above the bottom of feed door opening.
  - c.) Stir the coal and watch the fire. Be sure the new coal is burning briskly before you close the doors and turn the thermostat down.
  - d.) Shake grates vigorously 1/2" left to right to spill ashes into the ash pan. Do this at least once every 12 hours of operation. Empty ash pan regularly. Do not allow ashes to build-up to grate as grate will warp and burnout, and you might spill the ashes when removing the pan. Dispose of hot ashes properly.
  - e.) Rotation of the handle (5 o'clock to 7 o'clock) position will agitate coals and spill ashes into ash pan.
  - f.) It is advisable for you to get familiar with the shaker grate operation before firing.

## Service Hints

**Do not expect a furnace to draw. It is the chimney that creates the draft. Smoke spillage into the house or excessive build-up of water or creosote in the chimney are warnings that the chimney is not functioning properly.** Correct the problem before using furnace. Possible causes are:

1. The connector pipe may be pushed into the chimney too far, stopping the draft.
2. Do not connect two furnaces or a stove and furnace into the same chimney flue.
3. The chimney used for a furnace must not be used to ventilate the cellar or basement. If there is a cleanout opening at the base of the chimney, it must be closed tightly.

4. If the chimney is operating too cool, water will condense in the chimney and run back into the furnace. Creosote formation will be rapid and may block the chimney. Operate the furnace at a high enough fire to keep the chimney warm, preventing this condensation.
5. If the fire burns well, but sometimes smokes or burns slowly, it may be caused by the chimney top being lower than another part of the house or a nearby tree. The wind blowing over a house or a tree, falls on top of the chimney like water over a dam, beating down the smoke. The top of the chimney should be at least 3 feet above the roof and be at least 2 feet higher than any point of the roof within 10 feet.
6. See page 18 for list of trouble shooting tips.

A draft reading of .05 to .06 w.c. is suggested for proper burning of this unit when using wood or bituminous coal as fuel. When using anthracite coal, this draft reading is a minimum reading.

## Chimney Maintenance

Creosote and Soot - Formation and Need for Removal

When wood is burned slowly, it produces tar and other organic vapors, which combine with expelled moisture to form creosote. The creosote vapors condense in the relatively cool chimney flue of a slow-burning fire. As a result, creosote residue accumulates on the flue lining. When ignited, this creosote makes an extremely hot fire.

When coal is burned, the products of combustion combine with moisture to form a soot residue which accumulates on the flue lining. When ignited, this soot makes an extremely hot fire.

The chimney should be inspected at least twice monthly during the heating season to determine if a creosote or soot build up has occurred.

If creosote or soot has accumulated, it should be removed to reduce the risk of a chimney fire.

Chimney fires burn very hot. If the chimney catches fire, immediately call the fire department, then reduce the fire by closing the inlet air control. Pour a large quantity of coarse salt, baking soda or cool ashes on top of the fire in the firebox.

### CAUTION

**A chimney fire may cause ignition of wall studs or rafters which you thought were a safe distance from the chimney. If you have a chimney fire, have your chimney inspected by a qualified person before using again.**

# Trouble Shooting Tips for Warm Air Furnace

## 1. Problem:

*Smoke puffs from furnace*

### Solution:

- A. Check chimney draft. Check for blocked chimney or flue pipe. Use mirror to check chimney clearance.
- B. Check ash pit — if it is too full, empty.
- C. Make sure furnace room is not too airtight.
- D. Make sure all of chimney mortar connections are airtight.
- E. Check ash drawer. Make sure it's airtight.
- F. Check chimney for possible down-draft caused by taller surrounding trees or objects. Correct with proper chimney vent cap.
- G. Check the possibility of a cold chimney forcing cool gases backward. Remedied by properly insulating chimney with non-combustible liner — non-combustible insulation.
- H. Fuel may be too green.
- I. Make sure no other fuel burning devices are connected to the chimney impairing the draft.
- J. Check chimney draft, it should be .06 inches of water column. This service is provided by a certified chimney sweep.

## 2. Problem:

*Inadequate heat being delivered to your home*

### Solution:

- A. Check home insulation — is it adequate?
- B. Check hook-up to furnace — is it installed correctly?
- C. Cool air inlet may be inadequate or furnace room too airtight.
- D. Your wood fuel may be too low grade. Hardwoods are recommended.
- E. Make sure your hot air duct (and other duct work) is airtight.
- F. If furnace room is warm but your home isn't, check back draft dampers.
- G. Is air to the blower available?

## 3. Problem:

*Excess smoke or flames coming out door when refueling*

### Solution:

- A. Wait 15 seconds and open door SLOWLY — then refuel.
- B. Check length of flue pipe to chimney. Your unit should be within six (6) feet of your chimney.
- C. Make sure chimney cap is not too close to the top of the chimney.
- D. Check chimney draft — make sure chimney flue pipe is clean and chimney is of adequate height.

- E. Make sure you're not suffocating the fire with excessive amounts of unburned wood.

- F. Slide baffle should be pulled out prior to load door opening.

## 4. Problem:

*Distribution blower vibrating*

### Solution:

- A. Tighten blower wheel to motor shaft.
- B. Check for bad fan bearings.

## 5. Problem:

*Distribution blower continues to run or will not run*

### Solution:

- A. Check fan limit or heat sensor and cable.
- B. Check to see that blower is properly wired. (See Wiring and Assembly Instructions).
- C. Check fuse box or power source.
- D. Check power supply.

## 6. Problem:

*Odor from first fire*

### Solution:

- A. The odor from new steel should disappear in a few hours.
- B. If the odor remains, call you dealer immediately. A bad weld can cause a fume leak.

## 7. Problem:

*Excessive Creosote*

### Solution:

- A. Check the grade of wood you are burning.
- B. Make sure your unit is serviced by its own proper chimney.
- C. Check length of flue pipe and its connections.
- D. Make sure you are burning the smallest, hottest fire to adequately heat your home.
- E. Also see Solutions to Problem one.

## 8. Problem:

*If the fire goes out or does not hold over night*

### Solution:

- A. Poor Draft.
- B. Incorrect damper settings.
- C. Improper firing methods if burning coal.
- D. More combustion air needed.
- E. Coal not sized to the furnace. We recommend 1" to 3" diameter pieces of coal.
- F. Ashes, if allowed to accumulate in the ash pit, will not allow passage of the required air for combustion. Keep ash pit clean.
- G. This furnace is not to be used with an automatic stoker unless so certified.