

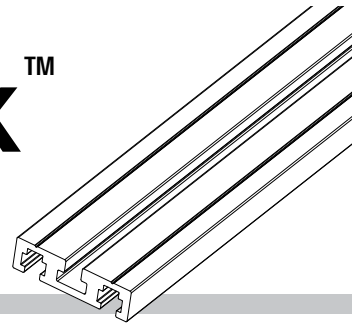

Klamp Trak™ Instructions



ITEM# KKS1020 - Klamp Trak™

Getting Started

There are three main methods for installing Klamp Trak™ in your workshop. In all three methods, your goal will be to construct an opening with the same (or slightly larger) dimensions as the Klamp Trak™, directly below your intended work surface. This will allow the trak to sit flush-with or slightly below the main surface, keeping your work surface clear of obstacles. Klamp Trak™ dimensions can be found in the diagram on page 5 of this instruction manual.

Below are the three methods to choose from. Depending on how you intend to use your Klamp Trak™, determine the best choice for your specific situation.

- 1. Rout into edge of workbench (page 1)**
- 2. Add a 3/4" surface to the top of your workbench (page 2)**
- 3. Place between two staggered pieces of 3/4" plywood (page 3)**

• Rout into edge of workbench.

Good for adding fast-clamping capabilities to the edge of your current workbench.

1. Place the trak above the spot on the bench where you would like it to position it. Trace around the trak with a pencil.
2. Place your router on top of the Klamp Trak™ and drop the flat-tip bit to the table's surface. This will make your routing depth equal to the height of the trak.
3. Working from the outermost edge of your workbench, use the pencil marks as a guide as you rout in towards the center of the workbench. Working from the outside in will allow you to maintain a solid base under your router.
4. After you are done routing, remove any remnant material from the corners with a hammer and chisel.
5. Test the dimensions of your routing by placing the trak inside of the opening and checking to see that it rests flush with, or below the surface of your workbench. Make adjustments as necessary.

Tips

TIP: When routing, remember that your goal is for the trak to sit flush with, or slightly below the work surface. You may need to lower your bit depth slightly, to assure the Trak does not rest above your work surface.

TIP: Follow your router's instructions carefully.

Warning

WARNING: Do not rout this Trak into material less than 1.5" deep. Doing so could result in bolts being pulled through the surface or related damage to your work surface.

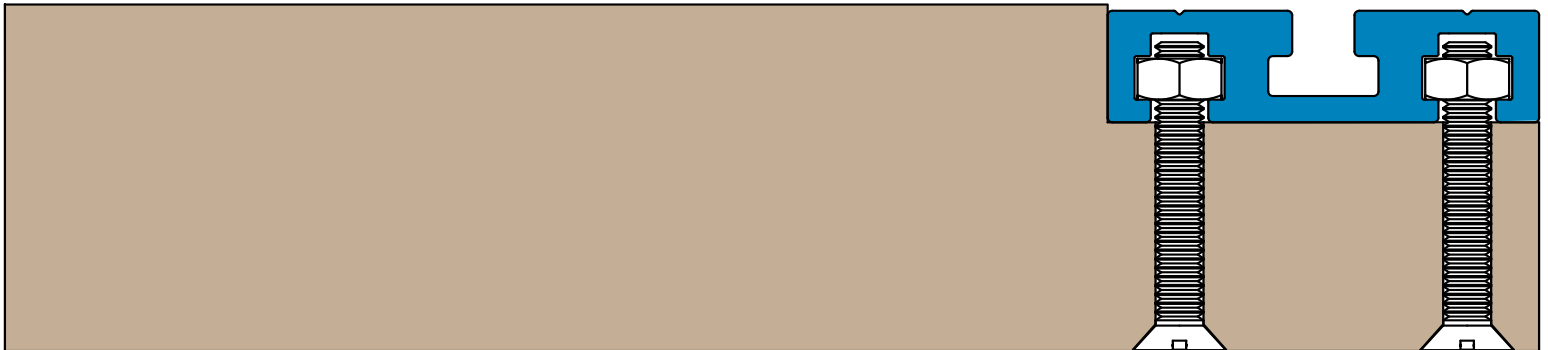

• Add a ¾" surface to the top of your workbench.

Good if you would like to eventually replace the top of your workbench or return it to its original condition.

1. The Klamp Trak™ is exactly .695" thick, or slightly thinner than most ¾" plywood, MDF, or other composite sheets. Begin by cutting your composite sheet to the same dimension as the top of your current workbench.
2. Place the trak on top of the sheet, where you would like it to be eventually positioned.
3. Trace around the trak using a pencil, and cut the appropriate material out using a saw of your choice.
4. Test the dimensions of your cut by placing the trak inside of the opening and checking to see that it rests flush with, or below the surface of your workbench. Make adjustments as necessary.
5. Secure the sheet to the top of your workbench using any method you wish. (Screws, nails, recessed hex bolts, countersunk flat-head bolts, etc.)
6. Re-test the dimensions and make adjustments as necessary.

Tip

TIP: If possible, attempt to secure the sheet to your workbench from the bottom side. This will eliminate the possibility of the screws becoming loosened and interfering with your flat work surface.



• Place between two staggered pieces of ¾" plywood.

Good if you wish to create a new and affordable workbench from scratch.

1. Place the trak on top of the upper sheet, where you would like it to be eventually positioned.
2. Trace around the trak using a pencil, and cut the appropriate material out using a saw of your choice.
3. Test the dimensions of your cut by placing the trak inside of the opening and checking to see that it rests flush with, or below the surface of your workbench. Make adjustments as necessary.
4. Secure the upper sheet to the lower sheet using any method you wish. (Screws, nails, recessed hex bolts, countersunk flat-head bolts, etc.)
5. Re-test the dimensions and make adjustments as necessary.

Tips

TIP: Securing the workpieces together from the bottom side will eliminate the possibility of the screws becoming loosened and interfering with your flat work surface.

TIP: Using material thicker than ¾" as the bottom piece will reduce the possibility of the bolts pulling through or related damage to the lower piece. 1" or more is recommended to fully anchor the trak. If you are using ¾" material, plywood is the only recommended material. MDF and other composites may not have the strength to support the pressures exerted on the bolts over time.



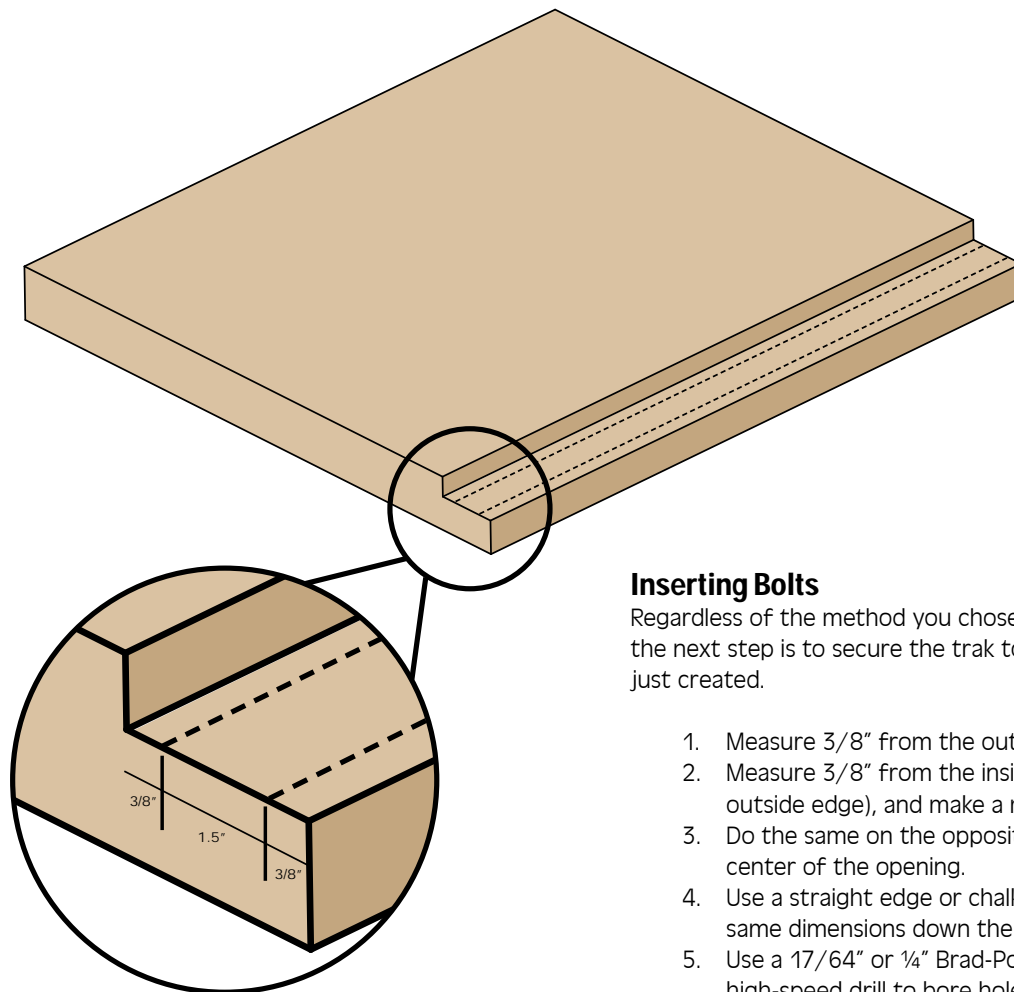

Inserting Bolts

Regardless of the method you chose to install the Klamp Trak™, the next step is to secure the trak to the opening that you have just created.

1. Measure $\frac{3}{8}$ " from the outside edge, and make a mark.
2. Measure $\frac{3}{8}$ " from the inside edge ($1\frac{7}{8}$ " from the outside edge), and make a mark.
3. Do the same on the opposite end of the trak, and at the center of the opening.
4. Use a straight edge or chalk line to place a line at these same dimensions down the entire length of the opening.
5. Use a $\frac{17}{64}$ " or $\frac{1}{4}$ " Brad-Point bit (for precision) and a high-speed drill to bore holes through center of each line. Place the first hole 1" from the edge, and each additional hole 4" from the last.

Kreg recommends a minimum of 2 bolts every 4" of track to ensure a strong connection.

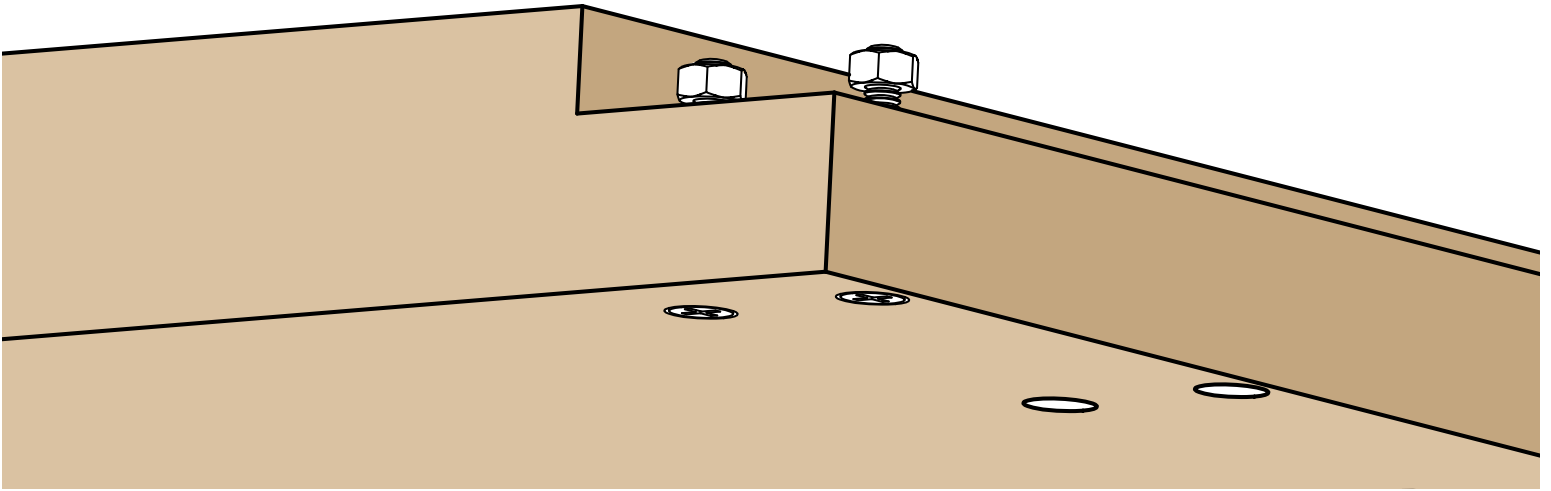

If you are using flat head bolts, you must first counter-sink the underside of each hole, and then insert the bolt up through the bottom of each hole. With the bolt protruding from the top side of the hole, begin to thread a $\frac{1}{4}$ " nut onto it until the bolt begins to protrude from the other side.

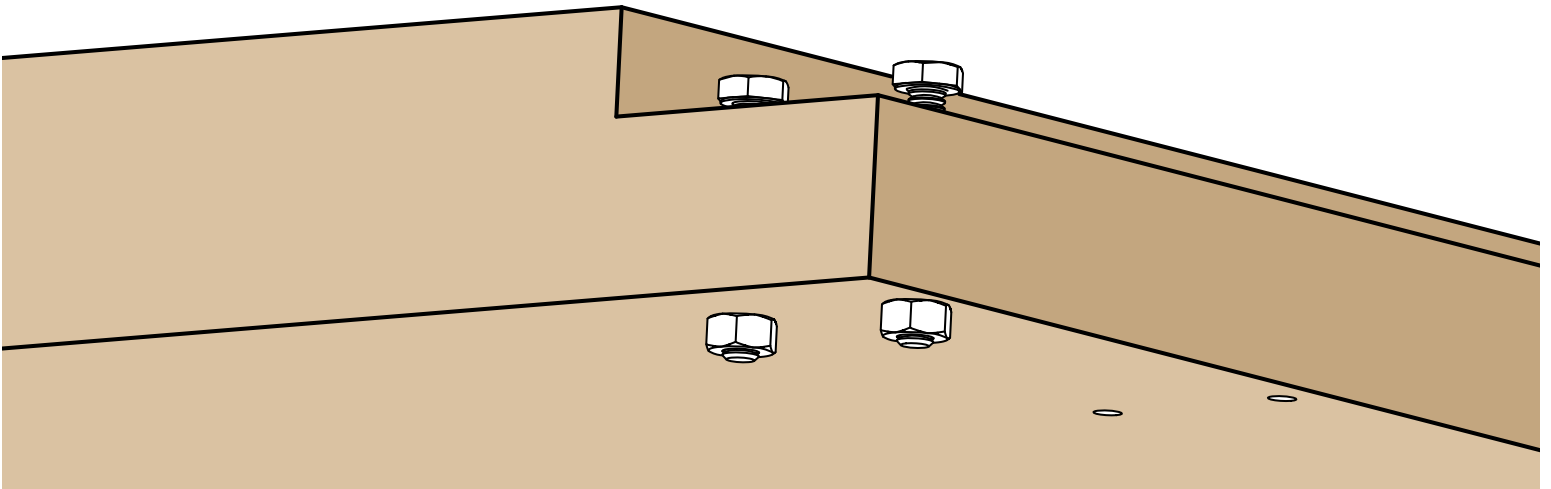

If you are using hex head bolts, insert the bolts down through the top of each hole and thread the nuts until the bolt begins to protrude from the other side.

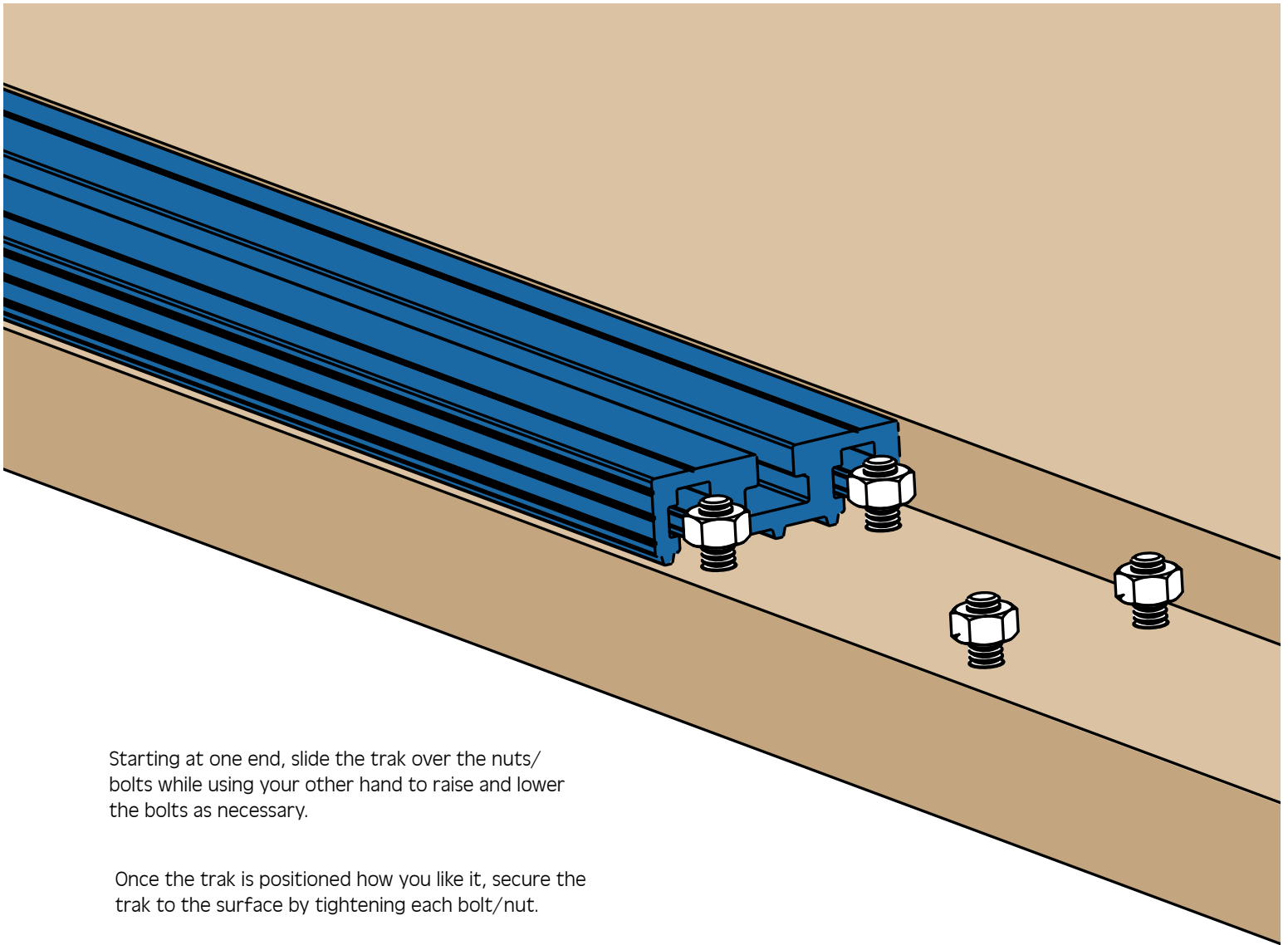

Starting at one end, slide the trak over the nuts/ bolts while using your other hand to raise and lower the bolts as necessary.

Once the trak is positioned how you like it, secure the trak to the surface by tightening each bolt/nut.

Tips

TIP: If you choose to use flat-head bolts, inserting up through the bottom of each hole, be sure to use the correct length of bolt. The must be long enough to reach the t-slot, and short enough to not extend past the t-slot when the nuts are fully tightened. To find the correct length of bolt, simply add the height of your table to the height of the t-slot, as shown at right.

For a less 'fussy' approach, use simple hex bolts inserted from the top of each hole, and tighten the nuts from the bottom side. This is easier and allows for the use of a larger variety of bolt lengths, but also leaves hardware extending past the base of the table. Choose the method that suites your needs the best.

Klamp Trak™ Specifications

